

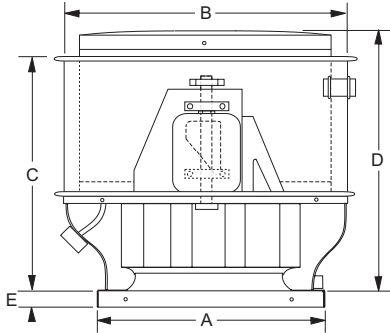

# MODEL TXB-RHUL

## UL762 LISTED RESTAURANT BELT DRIVE CENTRIFUGAL UPBLAST ROOF EXHAUSTER

P: 800.961.7370  
www.solerpalau-usa.com



SIZE	DIMENSIONS (IN.)					AVG. SHIP WT. (LBS)
	A	B	C	D	E	
30	42 1/2	56 3/4	41	45	2 1/2	365
36	42 1/2	66	44	48	2 1/2	365
42	55	72 1/2	48	52	2 1/2	385
48	55	78 3/4	52	56	2 1/2	490

A - Inside dimension of square curb cap.      D - Height of unit above top of curb.  
 B - Outside diameter of unit.                      G - Outside dimension of factory built prefab curb.  
 C - Height of exhaust opening above curb cap.



OPTIONAL      cULus 705  
(Must be specified)      cULus 762 (Grease)

### FAN FEATURES

- Exhaust air up to 35,000 CFM in high static pressure applications up to 3-1/4" w.g.
- Attractive spun aluminum exterior
- Belt drives permit easy performance adjustments when needed
- Non-overloading backward inclined wheel for efficiency at higher static pressures
- Roof or sidewall mounting options
- UL 705 listed
- UL 762 listed for Grease Removal

SIZE	METAL GAUGES				
	WIND BAND	MOTOR COVER	SHROUD	BASE	
				STD/UL	RHUL
30	.050	.050	.100	.090	16GA
36	.050	.050	.090	.090	16GA
42	.050	.050	.090	.100	N/A
48	.050	.050	.090	.100	N/A

FAN SPECIFICATIONS									MOTOR SPECIFICATIONS				
Line	Qty.	Model No.	Tag	CFM	SP	Fan RPM	BHP	Sones	HP	Volts	Phase	Hertz	Encl
1													
2													
3													
4													
5													

ACCESSORY ITEMS	1	2	3	4	5	ACCESSORY ITEMS	1	2	3	4	5
<input type="checkbox"/>						<input type="checkbox"/>					
<input type="checkbox"/>						<input type="checkbox"/>					
<input type="checkbox"/>						<input type="checkbox"/>					
<input type="checkbox"/>						<input type="checkbox"/>					
<input type="checkbox"/>						<input type="checkbox"/>					

Project: \_\_\_\_\_ Submitted: \_\_\_\_\_  
 Customer: \_\_\_\_\_ Approved: \_\_\_\_\_  
 Location: \_\_\_\_\_