



ADVANCING VENTILATION®

MODELS STXD, STXDe & STXDeRHUL

DIRECT DRIVE CENTRIFUGAL UPBLAST ROOF EXHAUSTERS

STXDe FEATURES

- cULus 705 Listed

STXDeRHUL FEATURES

- Galvanized steel base
- Electrical connection located on shroud side with weather proof junction box
- cULus 762

STANDARD FEATURES

- Exhaust air up to 4,780 CFM in high static pressure applications up to 2-1/4" w.g.
- Attractive spun aluminum exterior
- Direct drive units have low sound levels and quiet operation
- Curved non-overloading backward inclined wheel for efficiency at higher static pressures
- Roof or sidewall mounting options
- AMCA Air and Sound Licensed
- cULus 705 Listed
- NFPA - suitable for National Fire Protection Association Installations

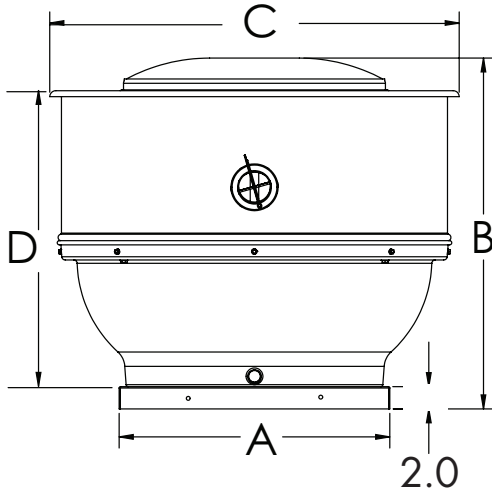

Ecowatt®
* Only for STXDe & STXDeRHUL

NOTE: All dimensions shown are in inches.

Size	A	B	C	D	Roof Opening	Curb O.D.	Damper O.D.	Approximate Weight (lbs)*
6	18	25 5/16	28 5/8	20 5/16	13 1/2	16 1/2	12	50
7	18	25 5/16	28 5/8	20 5/16	13 1/2	16 1/2	12	50
8	18	25 5/16	28 5/8	20 5/16	13 1/2	16 1/2	12	59
10	18	25 5/16	28 5/8	20 5/16	13 1/2	16 1/2	12	62
12	20	26 15/16	31 5/16	21 15/16	15 1/2	18 1/2	14	68
14	20	26 15/16	31 5/16	21 15/16	15 1/2	18 1/2	14	75
15	24	27 5/8	36 1/2	22 5/8	19 1/2	22 1/2	18	89
16	24	27 5/8	36 1/2	22 5/8	19 1/2	22 1/2	18	90
18	30	35 3/4	42 5/8	30 1/2	25 3/16	28 1/2	24	230

*Approximate unit weight includes the largest cataloged open drip proof motor, drives (if applicable), less crating.

FAN SPECIFICATIONS									MOTOR SPECIFICATIONS				
Line	Qty.	Model No.	Tag	CFM	SP	Fan RPM	BHP	Sones	HP	Volts	Phase	Hertz	Encl
1													
2													
3													

ACCESSORY ITEMS	1	2	3	4	5	ACCESSORY ITEMS	1	2	3	4	5
<input type="checkbox"/>						<input type="checkbox"/>					
<input type="checkbox"/>						<input type="checkbox"/>					
<input type="checkbox"/>						<input type="checkbox"/>					

Subject to change unless approved in submittal by S&P
STXD-STXDe-STXDeRHUL-Submittal_04052022

