



P: 866.733.0233
www.solerpalaucanada.com

MODEL LSF FILTERED SUPPLY FAN with LOUVERED HOUSING

STANDARD FEATURES

- AMCA Air Licensed.
- cULus Listed - Standard 705 (Optional).
- Disconnect standard (Except two speed and explosion proof).
- Heavy-gauge galvanized construction (Louvered Aluminum).
- Statically and dynamically balanced forward curved wheel.
- Variable pitch drives standard.
- Drives sized for a minimum of 150% of drive horsepower.
- 5-year fan, and 1-year motor warranty.
- Heavy-duty L50 200,000 hour rated pillow block bearings.
- Low profile.
- Integral deep spun inlet.

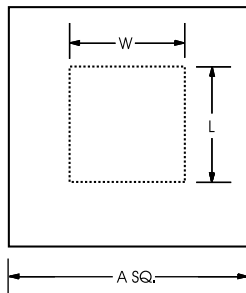

Discharge Opening

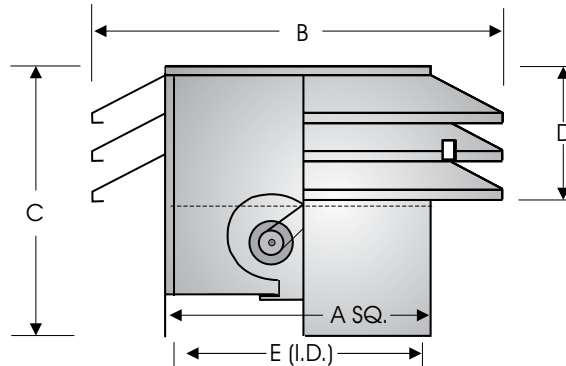

| Size | Housing O.D. A | Overall Width B | Overall Height C | D | No. Tiers | E (Curb Cap I.D.) | W | L | Filters (Qty) |
|------|----------------|-----------------|------------------|--------|-----------|-------------------|--------|--------|---------------------|
| 9 | 24-1/2 | 37-3/4 | 23-3/4 | 16-1/8 | 3 | 24 x 24 | 12 | 10-1/2 | 16 x 20 (4) |
| 10 | 28-1/2 | 41-3/4 | 23-3/4 | 16 | 3 | 28 x 28 | 13-1/4 | 11-5/8 | 16 x 25 (4) |
| 12 | 28-1/2 | 41-3/4 | 30-1/2 | 16 | 3 | 28 x 28 | 15-7/8 | 13-5/8 | 16 x 25 (4) |
| 15 | 32-1/2 | 45 | 32 | 1/ | 4 | 32 x 32 | 18-7/8 | 16-1/4 | 21-1/2 x 28 (4) |
| 18 | 36-1/2 | 50 | 38-5/8 | 23 | 5 | 36 x 36 | 22-1/4 | 19 | 24 x 30 (4) |
| 20 | 51-1/4 | 65 | 47 | 26 | 5 | 51 x 51 | 23-1/8 | 25 | 25-1/2 x 45-1/2 (8) |

Roof Curb Dimensional Data

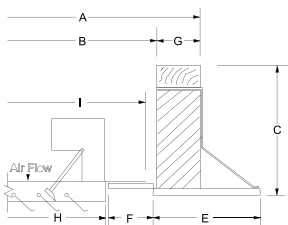

| Size | Prefab Curb O.D. A | Prefab Curb I.D. B | Curb Height C | E | F | G | H | I |
|------|--------------------|--------------------|---------------|---|-------|-------|----|----|
| 9 | 22-3/4 | 19-1/2 | 8 | 7 | 1-1/2 | 1-1/2 | 16 | 19 |
| 10 | 26-1/2 | 23-1/2 | 8 | 7 | 1-1/2 | 1-1/2 | 20 | 23 |
| 12 | 26-1/2 | 23-1/2 | 8 | 7 | 1-1/2 | 1-1/2 | 20 | 23 |
| 15 | 30-1/2 | 27-1/2 | 8 | 7 | 1-1/2 | 1-1/2 | 24 | 27 |
| 18 | 34-5/8 | 31-3/8 | 8 | 7 | 1-1/2 | 1-1/2 | 27 | 30 |
| 20 | 49 | 46 | 8 | 7 | 1-1/2 | 1-1/2 | 42 | 45 |

Duct Adaptor Dimensional Data

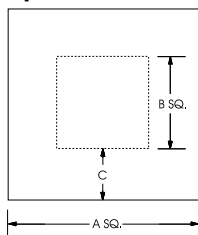

| Size | A Sq. | B Sq. | C (Out to In) |
|------|--------|--------|---------------|
| 9 | 18-1/2 | 14-1/2 | 2 |
| 10 | 22-1/2 | 18-1/2 | 2 |
| 12 | 22-1/2 | 18-1/2 | 2 |
| 15 | 26-1/2 | 20-1/2 | 3 |
| 18 | 30-1/2 | 24-1/2 | 3 |
| 20 | 45 | 30 | 7-1/2 |



| FAN SPECIFICATIONS | | | | | | | | | MOTOR SPECIFICATIONS | | | | |
|--------------------|------|-----------|-----|-----|----|---------|-----|-------|----------------------|-------|-------|-------|------|
| Line | Qty. | Model No. | Tag | CFM | SP | Fan RPM | BHP | Sones | HP | Volts | Phase | Hertz | Encl |
| 1 | | | | | | | | | | | | | |
| 2 | | | | | | | | | | | | | |
| 3 | | | | | | | | | | | | | |

| ACCESSORY ITEMS | 1 | 2 | 3 | 4 | 5 | ACCESSORY ITEMS | 1 | 2 | 3 | 4 | 5 |
|--------------------------|---|---|---|---|---|--------------------------|---|---|---|---|---|
| <input type="checkbox"/> | | | | | | <input type="checkbox"/> | | | | | |
| <input type="checkbox"/> | | | | | | <input type="checkbox"/> | | | | | |
| <input type="checkbox"/> | | | | | | <input type="checkbox"/> | | | | | |

Subject to change unless approved in submittal by S&P.
LSF_Submittal_0107(InDesign, pg1)