

MODEL SWF

SIDEWALL CENTRIFUGAL FAN



MODEL FEATURES

- Exhaust air up to 416 CFM with static pressure capabilities to 1.5" w.g.
- Galvanized steel casing with black backed enamel coating
- Pre-wired junction box
- Ideal for applications where space is limited
- Non-overloading backward inclined wheel for efficiency at higher static pressures
- cULus Listed

MODEL OVERVIEW

The SWF series utilizes the same powerful (high static) motor found in the popular PV Series fans, yet the SWF series is encased in an exterior mounted housing. The outdoor rated exterior housing provides easy access from the outside of a building or dwelling. This makes the SWF a great solution for installations where attic space or easy indoor access is difficult and not suitable for traditional PV style in-line mounting. The Sidewall Fan Series (SWF) of direct drive centrifugal ventilation fans consists of five model sizes ranging from 4-8". All models are designed for direct connection in-line with standard diameter round ducting. Airflow performance values range from 119 CFM up to 416 CFM.

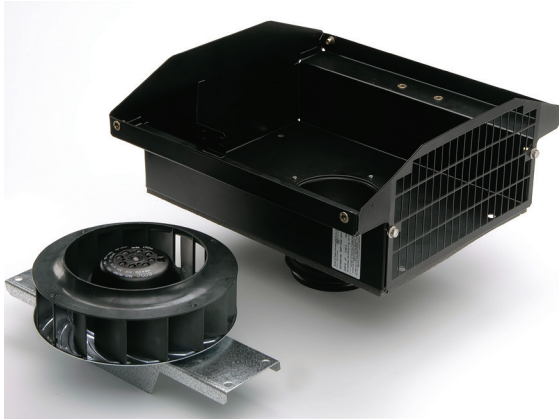

All SWF series models incorporate a powerful external rotor motor that has been factory matched to a non-overloading backward curved centrifugal fan wheel.

This powerful combination enables the SWF to deliver exceptional airflow performances against high static pressure typically found in ducted ventilation systems. All motors within the SWF series are fully speed controllable using voltage or frequency control regulators.

The SWF series has been designed for easy through the wall installation. The totally enclosed motor design allows for the SWF to operate in high moisture, lint and dust laden

air. All models are manufactured with high quality materials and workmanship that is supported by a comprehensive **five (5) year warranty**.

The SWF series features a corrosion resistant galvanized steel casing with a baked enamel coating that can be painted to match the exterior wall. The unit also includes a built-in backdraft damper and an extended opening exhaust grille. The larger grille allows for the easy exhaust of "dirty" or lint laden air while the spring-loaded backdraft damper helps prevent insects, etc. from entering duct work.



Built-in Spring-loaded Backdraft Damper

Model SWF is available in our Quickship program. All sizes are available for next day shipping from stock.



5 year fan housing and motor warranty

All specifications are subject to change without notice unless approved in submittal by Soler & Palau.



CONSTRUCTION/SPECIFICATION CHECKLIST

Casing

- Manufactured from high grade pressed galvanized steel, with baked enamel coating.
- Removable top for easy access to motor for cleaning or inspection.
- Large grille opening for easy passing of lint and other potentially clogging materials.
- Supplied with a prewired junction box.

Wheel / Impeller

- Backward curved centrifugal type.
- Factory matched to an external rotor motor and dynamically balanced to eliminate vibration.

Motor

- Totally enclosed permanent split capacitor start and run external rotor motors.
- 115V 60Hz (single phase) electrical connection.
- Permanently sealed, self lubricating precision ball bearings.
- Safety Thermal Overload Protection Cut-Out (Automatic Reset Type).
- All Models are suitable for working airstreams up to 140° F

Code Approval

- All models have been independently safety tested by Underwriters Laboratories, Inc. and are UL and cUL Listed.
- The SWF product range is certified by the Home Ventilating Institute (HVI) for Air Performance.

ACCESSORIES



SC 15
Variable speed
control



BOC/BOR
Interior Air Valve



SPT-100x
Pressure Switch



CS-325
Current Sensor

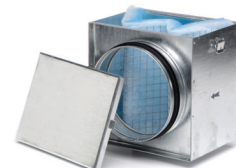

MFL
Filter Box

Please refer to the S&P Group A (Residential/Light Commercial) catalog for a complete line of accessories.



PERFORMANCE/DIMENSIONS

Dimensions in inches/mm

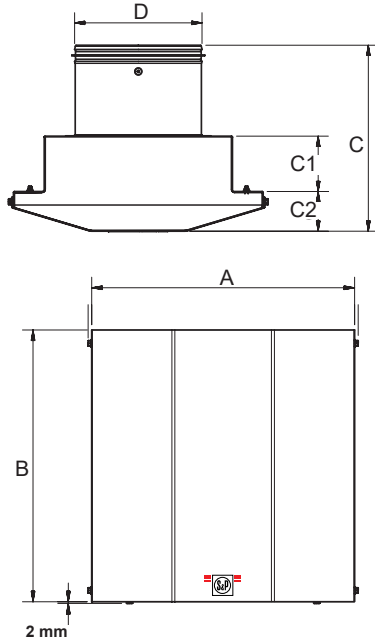

Model	A	B	C	C1	C2	D
SWF-100	13 1/4 337	13 1/4 337	9 228	3 76	2 7/16 62	4 100
SWF-100x	13 1/4 337	13 1/4 337	9 228	3 76	2 7/16 62	4 100
SWF-150	15 1/2 394	13 1/4 337	10 3/16 256	3 76	2 7/16 62	6 150
SWF-150x	15 1/2 394	16 1/16 408	10 254	3 3/16 81	2 7/16 62	6 150
SWF-200	15 1/2 394	16 1/16 408	11 7/16 290	3 3/8 87	2 7/16 62	8 200

Air Performance

Model	RPM	Volts	Frequency	Current	Watts	CFM vs. Static Pressure (SP) Ins. WG								
						0"	0.125"	0.25"	0.375"	0.5"	0.75"	1.0"	1.25"	1.5"
SWF-100	2200	120	60 Hz	0.52 A	57	119	106	92	78	64	44	26	-	-
SWF-100X	2600	120	60 Hz	0.8 A	90	171	162	152	142	118	90	66	46	28
SWF-150	2600	120	60 Hz	0.8 A	90	235	221	197	181	168	122	81	60	27
SWF-150X	2800	120	60 Hz	1.0 A	115	354	332	310	287	266	230	192	147	96
SWF-200	2800	120	60 Hz	1.0 A	115	416	395	368	341	324	287	233	184	132



Sound

Fan sound levels are measured in sones. At this time there are no sone level test standards available through HVI due to the fact that remote mounted fan noise levels are in proportion to the following: type of duct, length of duct, fan distance from the intake source and other random factors. It is generally accepted that remote mounted venting is quieter than standard (in room) venting.



BATHROOM EXHAUST GRILLES FOR INLINE FANS

Featuring Vent Lights and Premium Grilles

S&P's Grille Options give you the choice of seven (7) aesthetically pleasing grilles designed to match any bathroom decor. You can choose from our Vent Lights, Premium Grilles or Adjustable Grilles to fit your needs.

These grilles are designed to be used exclusively with one of S&P's remotely mounted inline fans (TD, PV, SWF) for virtually silent bathroom ventilation. Inline fans give you the option to mount your grille over the shower, toilet, tub, or in multiple locations (dual vent).

With S&P's Grille Options the choice is yours!

Vent Lights Available with LED Bulbs



S&P's new Vent Lights give you ventilation that is "Out-of-Sight and Out-of-Mind"! The Vent Lights appear to be a regular can light, and when combined with a remotely mounted fan, the noise and unsightly look of the traditional bathroom fan are gone! The Vent Lights are aesthetically pleasing grilles with lights that will match any bathroom decor.

Model	Description
VLED-100	Vent Light with PAR30 LED Bulb
VLH-100	Vent Light with PAR30 Halogen Bulb
VLF-100	Vent Light with Energy Star Rated Compact Fluorescent Bulb

Dimensions (inches)

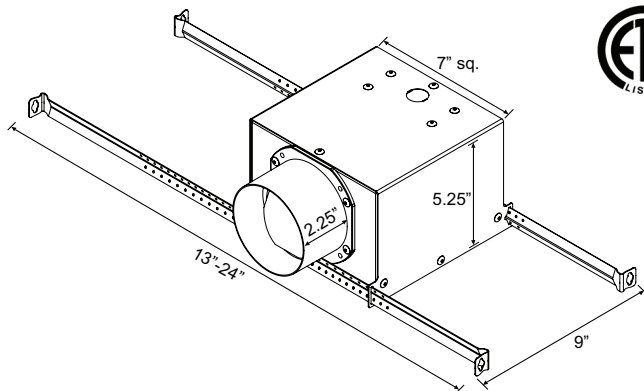

Features:

- Longer duct collar for 4" duct
- Extendable hanger bars up to 24"
- 7.5" grille
- Built-in backdraft damper
- 3 bulb options

Why Choose the Vent Light with LED Bulbs?

S&P's respect for the environment extends to its Vent Lights with the optional LED Bulb. The benefits to the LED Bulbs include:

- Built to last a minimum of 60,000 hours, plus the LED's use a fraction of the energy that a traditional incandescent or halogen lamp uses
- LED's contain no mercury so they are easy to dispose of, unlike other energy efficient bulbs
- The LED lamps run cool and are shock resistant, making them safer for use in your home



Premium Grilles

PG



S&P's premium grilles come standard with steel collars for easy mounting and installation.

Model	Description
PG-100	4" Plastic Grille with 4" Steel Collar
PG-150	6" Plastic Grille with 6" Steel Collar

Grille Dimensions (in inches)



Grille	Dia.	Height	Fits Duct Dia.	Fits Collars
PG-150G	8 1/8	1 5/8	6"	PG-150D
PG-100G	4 5/8	1 1/2	4"	PG-100D

Collar Dimensions (in inches)

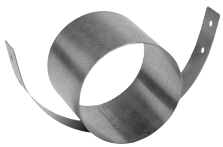

Collar	Diameter	Length
PG-100D	3 3/4	3 1/4
PG-150D	5 3/4	4 5/8

PG Collar

Adjustable Grilles

BOR/BOC



Exhaust grilles for bathrooms, toilets and other small rooms. All models offer an adjustable central valve to regulate the airflow.

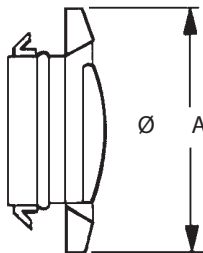
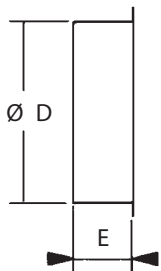

Model	A	D	E	Weight (lbs)
BOR/BOC-100	145	100	50	1
BOR/BOC-125	145	125	50	1
BOR/BOC-150	204	160	50	1
BOR/BOC-200	244	200	50	1



ADDITIONAL GENERAL ASSEMBLY ACCESSORIES



BOR/BOC
Round plastic/metal adjustable grille

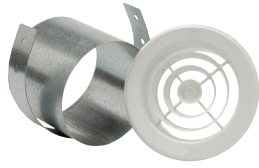

PG
Round grille without built-in backdraft damper



MBR
Connection Flanges



PER-W
Plastic louver shutter



PER
High pressure aluminum louver shutter



GRA
Aluminum exterior fixed grilles

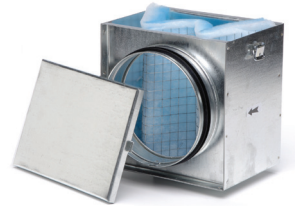

MFL
Filtering Box



SR
Reducer



SY
Y sheet metal adapter



ID
Flexible round duct



SIL
Acoustic attenuators

Electrical accessories



EPBT
Electronic push button timer

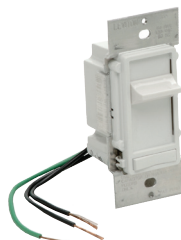

SCS
Speed control slide type



SC
Speed control



KIT - CLOTHES DRYER BOOSTING KITS

FEATURING PV-100x FANS

If you have a dryer with long or complicated duct runs, S&P offers the perfect solution to increase dryer efficiency: the PV100x Dryer Booster Fan. The PV100x has been specifically designed to handle dryer boosting applications when overcoming long or complicated duct runs. This system helps save on drying time, moisture build-up, wear and tear on your dryer, and helps save on your electric bill. The centrifugal blade design is able to overcome extreme resistance from the most challenging installations. The PV-100x offers a fully enclosed motor, which ensures a long, trouble free life; thus making it the right choice for enhancing the performance of your clothes dryer.

The PV-100x fan is available separately or as part of a kit that includes everything necessary for a hands-free operation. Once the system is installed you will no longer waste time, energy or unnecessary wear and tear on your dryer. The next step is to select which activation best fits your needs.

How to activate the PV-100x fan for clothes dryer boosting



NOTE

The PV-100x Dryer Booster fan is suitable for use with duct runs of up to 105 linear feet of 4" rigid duct or a maximum of 6 elbows and 80 feet.



PV-100xps

Pressure Switches

Pressure switches are a viable method of fan activation and a good solution for many installations. The pressure switch senses the pressure differential in the duct created by the dryer operation, thus activating the fan. Conversely, when the dryer is deactivated, the pressure switch senses this differential and the fan is deactivated. S&P's PV-100xps utilizes a compact pressure sensor and run timer enclosed within the junction box and mounted to the fan housing. The pressure sensor is also available as an accessory.



DBF-100xc

Current Sensors

Current sensors are S&P's "preferred" method of activation. They are "fail-safe", as there is no maintenance required on the current sensor and they're easy to install. The current sensing device can be installed at the outlet (where the dryer plugs into the wall) or at the circuit breaker box. When the device senses current going to the dryer, it activates the fan and vice-versa. No thought! No maintenance! Our choice!



IL-115/230

Interlocks

Interlocks, like Current Sensors, are another "fail-safe" method of clothes dryer booster activation. The interlocks senses when the fan is running and activates the dryer. Used as a safety feature, if the fan is not running or if there is a problem with the fan the dryer will not turn on.

All 3 activation methods are available as accessories or in the S&P's all inclusive dryer booster kits.



SWF - Sidewall Mount Exhaust Fan for Dryer Boosting



The sidewall unit can be paired with a current sensor or pressure switch when interior duct access in a home, apartment or townhouse is limited or difficult. The expanded exhaust grille allows for the easy passing of lint laden air. The SWF utilizes the same powerful motor as the PV-100x and is also suitable for duct runs up to 105 feet or up to 80 feet with 6 elbows. The low profile SWF fan is easy to install with an epoxy coating that can be painted to match the exterior of the building. The SWF also offers the same trusted 5 year warranty.

