



MODELS SDBD & SDBDe

DIRECT DRIVE CENTRIFUGAL DOWNBLAST ROOF EXHAUSTERS



MODEL FEATURES

- Exhaust air up to 4,980 CFM in high static pressure applications up to 1-3/4" w.g.
- Attractive spun aluminum exterior
- Direct drive units have low sound levels and quiet operation
- Curved non-overloading backward inclined wheel for efficiency at higher static pressures
- AMCA Air and Sound Licensed
- cULus 705 Listed
- Miami-Dade NOA, Florida Product Approval, and Texas Department of Insurance Listing option available

MODEL OVERVIEW

Model SDBD direct drive fans are designed to exhaust air up to 4,980 CFM in high static pressure applications to 1-1/2". The spun aluminum exterior provides an attractive appearance. The non-overloading backward inclined wheel with its higher static pressure capability makes this unit suitable for either ducted or nonducted applications. Its roof mounting permits location near the area to be ventilated, allowing short duct runs and more efficient operation.

Model SDBD is available in our Quickship program. .



The SDBD is generally used to exhaust air from all types of commercial and institutional buildings such as hospitals and health care facilities, schools, recreational buildings, machinery and equipment rooms, offices, retail stores and similar applications.

DIMENSIONS

SDBD Sizes 6, 7, 8, & 10

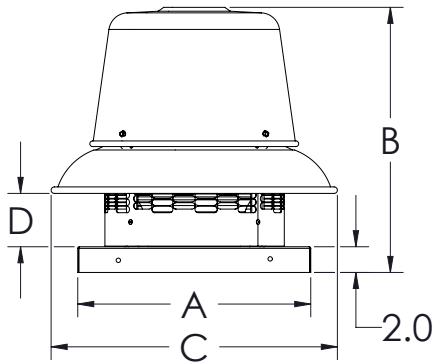

SDBD Sizes 12, 14, 15, & 16

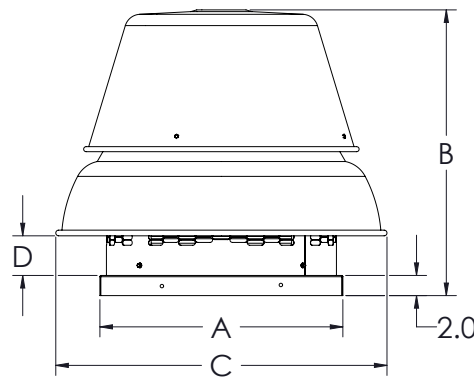

Size	A	B	C	D	Roof Opening	Curb O.D.	Damper O.D.	Average Ship Wt. Lbs.
6	18	14 1/8	22 5/16	1 1/2	13 1/2	16 1/2	12	27
7	18	16 13/16	22 5/16	4 1/8	13 1/2	16 1/2	12	30
8	18	20 1/2	22 5/16	4 1/8	13 1/2	16 1/2	12	42
10	18	20 1/2	22 5/16	5 1/8	13 1/2	16 1/2	12	46
12	20	27 5/16	27 5/8	3 7/8	15 1/2	18 1/2	14	105
14	20	27 5/16	27 5/8	3 7/8	15 1/2	18 1/2	14	112
15	24	28	32 7/8	4	19 1/2	22 1/2	18	136
16	24	28	32 7/8	4	19 1/2	22 1/2	18	136

Industry best 5 year fan housing warranty, 1 year motor warranty



eMotor - Electronically Commutated Motor

S&P's eMotor is 115/230V and 50/60 Hz and is available in 1/3, 1/2, 3/4, & 1 HP. This fully controllable motor offers both reliability and low maintenance in one of the most efficient motor fan combinations in the industry.

When used in S&P's SDBDe downblast fan, the eMotor is the ideal solution for a low cost, fully controlled ventilation system. This motor in the SDBDe can exhaust air volume up to 3,000 CFM, equal to that of a belt drive fan, with all the benefits and low maintenance of a direct drive fan.



Features and Advantages

- Easy speed control by DC 0-10 V variation or EC style speed controller
- Motor has motor mounted potentiometer with digital readout for easy speed adjustment
- Unit can be controlled by a PC or building management system
- Motor has 80% usable turndown vs. 30% on a PSC motor
- Internal motor circuitry converts 115/230 V single phase AC power to DC voltage for increased efficiencies.
- Centrifugal downblast roof fans with EC motors
- Motor is 115/230 V and 50/60 Hz
- cULus 705 Listing
- Ecowatt[®]

SDBDe with 1/2 HP Motor - Continuous Ventilation

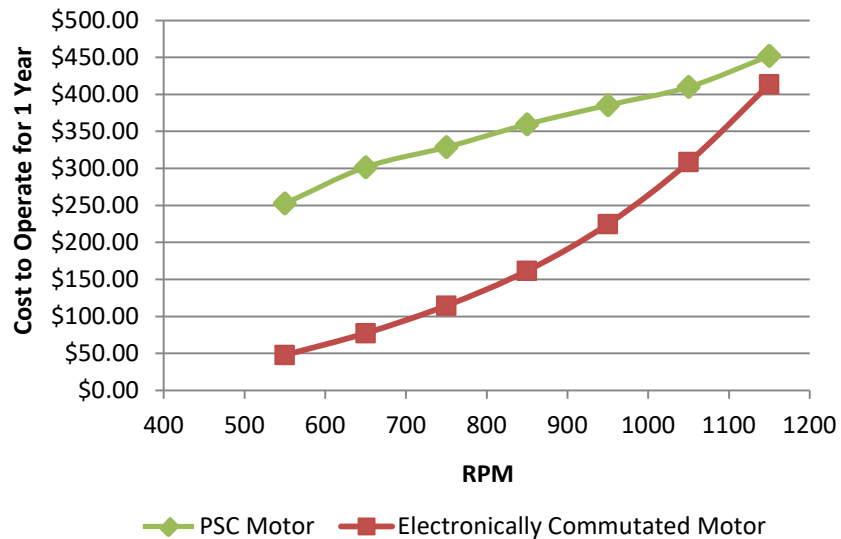

Cost to Operate Motors @ 650 RPM Continuous Ventilation

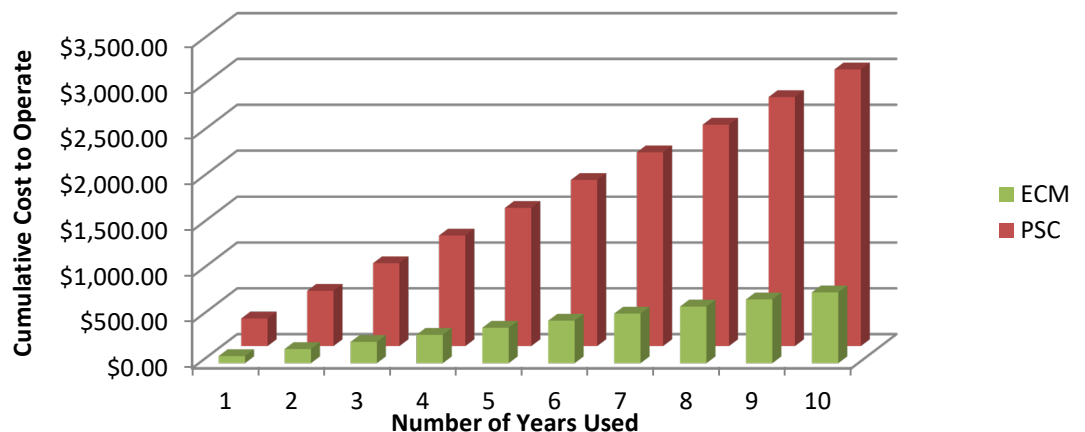



MODELS SDBD & SDBDe

DIRECT DRIVE CENTRIFUGAL DOWNBLAST ROOF EXHAUSTERS

Model SDBD & SDBDe - Direct Drive

Size Range	6, 7, 8, 10, 12, 14, 15 & 16
Motor HP Range	1/25 to 1-1/2
CFM Range	40 to 4980
Static Pressure	up to 1-3/4 in. w.g.
Warranty	5 years

*Models SDBDe have Electronically Commutated (EC) Motors





MODELS SDBD & SDBDe

DIRECT DRIVE CENTRIFUGAL DOWNBLAST ROOF EXHAUSTERS

#	Feature	Description
1	Motor Cover	Heavy-gauge aluminum motor cover provides weather protection for motor compartment.
2	Motor Cover Cap	Heavy-gauge aluminum top with rolled bead for added strength.
3	Motor	Open drip-proof enclosure standard, many other options available.
4	Bearings	Air handling ball bearing type with cast iron housing and grease fittings.
5	Vibration Isolators	Neoprene (rubber) vibration isolators to reduce vibration and noise.
6	Motor Mounting Plate	Heavy-gauge galvanized motor mounting plate.
7	Wheel	Aluminum, non-overloading, backward-inclined curved centrifugal wheel for maximum efficiency. Each wheel is dynamically balanced for smooth operation and long life.
8	Cooling Vanes	Helps promote cooling of the motor and drive by pulling air through the motor compartment. Helps maximize the life of the motor and drives.
9	Curved Blades	Designed to provide more CFM per HP and lower sound levels.
10	Support Legs	4 heavy-gauge galvanized support legs to anchor the motor plate to the fan base for stability and vibration reduction.
11	Fan Skirt	Aluminum fan skirt with rolled bead for extra strength. Fan skirt directs the exhausted air downward.
12	Birdscreen	Aluminum birdscreen standard to protect the fan from birds and other large objects.
13	Inlet Venturi	Deep spun single piece inlet venturi for optimum air and sound performance
14	Curb Cap	Fully welded curb cap for rigidity and weather protection. Pre-punched mounting holes for ease of installation.
15	Drives	Sized for 150% of drive HP, adjustable pitch motor sheaves.
16	Lifting Lugs	Standard on all belt drive models, SDB, for easy and safe placement of the fan on roof.
17	Disconnect Switch (not shown)	Standard with ODP and TE single speed motors. Ships loose.



OPTIONS/ACCESSORIES

Solid State Speed Control (SDBD): S&P's solid state control is matched to the motor and blower wheel to allow continuous reduction in performance allowing adjustments of airflow for system balancing. CFM is reduced in direct proportion to motor speed reduction. Speed control is available for 115 or 230 volt single phase. Exhauster performance can be controlled from the ventilated area.



Roof Curb: Prefabricated heavy-gauge galvanized steel, welded construction, 12" high (other heights are also available) with 1-1/2" wood nailer. Assures perfect fit of exhauster to roof opening. Options include burglar bars, single or double pitch construction and hinged curbs for easy duct access.

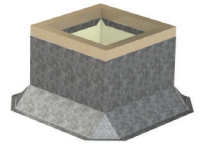

Sound Curb: Option of thermal acoustical lining or a complete maximum sound attenuating baffle system. Provision for mounting damper is available. Contact factory for information regarding effect on exhauster air performance and sound level.

Motor Operated Damper: Motor operated aluminum damper for positive closure against backdraft.



Automatic Damper: Automatic aluminum damper for ease in installation and effective backdraft protection.

Companion Gravity Units: Model RCX-II comes in a wide range of sizes and air capacities to provide relief or intake air to the system. Curbs and dampers are available to fit all sizes. Spun aluminum hoods provide a pleasing appearance, complementing the Model SDBD & SDB exhausters.

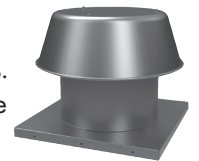

Special Coatings: Powered roof exhausters often require special coatings for protective and decorative purposes. Available coatings include: Synthetic Resin, Epoxy, and Heresite (air-dried phenolic). Contact your representative or the factory for more information on available coatings and colors.

Curb Hinge Arrangement: The curb hinge arrangement provides easy access to the exhaust fan, backdraft damper, and duct for servicing and cleaning.

Constant Pressure Control Options

Constant Pressure Controls: For constant pressure control applications, the S&P constant pressure control package is available. This package includes the components that are needed to complete a demand-based exhaust ventilation system for kitchens, bathrooms, and/or clothes dryer exhaust in multi-story buildings.

S&P recognized that the programming procedure for many constant pressure controls can be challenging, so this package is the simplest system available. The control box can be easily installed in the field, either mounted on a curb or inside the building. The backlit LCD display and pressure transducer are pre-programmed to work together to increase or reduce the speed of the fan to accommodate for the actual demand.



Control Box

Potentiometer Shipped Loose: If a variable rate that is manually changed by the operator from the occupied space is desired, the potentiometer is shipped loose and field installed in the appropriate accessible location. Simply rotating the dial will vary the speed of the fan from 20% to 100% full speed.



Sensor



Potentiometer



CONSTRUCTION/SPECIFICATION CHECKLIST

Housing

- Curb cap has integral deep spun inlet for efficient performance and prepunched mounting holes for ease of installation.
- Spun aluminum hood and skirt for weather protection and attractive appearance.
- Heavy-gauge motor support for rigidity and strength.
- Neoprene isolators for reduction of vibration and sound.
- Conduit passage for easy electrical connection from below roof.
- Aluminum birdscreen is standard.

Centrifugal Wheel

- All aluminum wheel
- Backward-inclined for efficiency at higher static pressure.
- Non-overloading for safe operation in ducted systems
- Curved blades for efficiency and quiet operation
- Dynamically balanced for smooth operation.

Speed Controllable Motors

- Brands are nationally recognized and locally serviced.
- Motors are single speed, speed controllable and drip-proof.
- All motors are rated for continuous duty.
- Disconnect is standard.
- Motors ship mounted as standard.

AMCA Seal

- Assures rating of Air and Sound performance.

UL Label

- UL 705 Listing assures electrical reliability.
- UL 705 must be specified when required.

MIAMI-DADE NOA, FLORIDA PRODUCT APPROVAL, AND TEXAS DEPARTMENT OF INSURANCE LISTING OPTION AVAILABLE

This model is designated to carry the Miami-Dade NOA and Florida Product Approval under Miami-Dade NOA# 20-1006.04 and Florida Product Approval FL37199. This model is also listed with the Texas Department of Insurance under Product Evaluation RV-126 for wind load and windborne debris resistance per IRC/IBC 2018. When this option is selected, the model will include tie downs, a fastened motor cover, and a reinforced birdscreen on the SDBD and SDB models. Curbs are required to be self-flashing, galvanized and 18 gauge steel.



HIGH WIND TIE DOWN KIT INCLUDES:

- Tie-downs
- Fastened motor cover
- Reinforced birdscreen on the SDBD and SDB models



PERFORMANCE

Sizes 6 & 7

Motor HP		RPM		Static Pressure in Inches w.g.								
				0	0.125	0.25	0.375	0.5	0.625	0.75		
SDBD6C 1/10 HP 1550 RPM	SDBDe6C 1/3 HP 1750 RPM	900	CFM	99	53	-	-	-	-	-	-	
			BHP	0.01	0.01	-	-	-	-	-	-	
			Sones	2.2	1.8	-	-	-	-	-	-	
		1050	CFM	116	78	-	-	-	-	-	-	
			BHP	0.02	0.02	-	-	-	-	-	-	
			Sones	3.3	2.8	-	-	-	-	-	-	
		1200	CFM	133	97	60	-	-	-	-	-	
			BHP	0.02	0.03	0.03	-	-	-	-	-	
			Sones	4.5	4.1	4.1	-	-	-	-	-	
		1350	CFM	149	116	88	-	-	-	-	-	
			BHP	0.03	0.04	0.04	-	-	-	-	-	
			Sones	5.6	5.1	5	-	-	-	-	-	
		1500	CFM	166	134	111	80	-	-	-	-	
			BHP	0.05	0.05	0.05	0.05	-	-	-	-	
			Sones	6.5	6	5.9	5.9	-	-	-	-	
		1650	CFM	182	153	131	107	71	-	-	-	
			BHP	0.06	0.07	0.07	0.07	0.07	-	-	-	
			Sones	7.4	7	6.9	6.8	6.9	-	-	-	
		SDBD6 1/10 HP 1550 RPM	SDBDe6 1/3 HP 1750 RPM	900	CFM	192	91	-	-	-	-	-
					BHP	0.01	0.01	-	-	-	-	-
					Sones	1.9	1.5	-	-	-	-	-
				1050	CFM	224	140	-	-	-	-	-
					BHP	0.01	0.01	-	-	-	-	-
					Sones	2.9	2.6	-	-	-	-	-
1200	CFM			256	183	97	-	-	-	-		
	BHP			0.02	0.02	0.02	-	-	-	-		
	Sones			4	3.7	3.5	-	-	-	-		
1350	CFM			288	224	156	-	-	-	-		
	BHP			0.02	0.02	0.02	-	-	-	-		
	Sones			5	4.7	4.5	-	-	-	-		
1500	CFM			319	262	202	133	-	-	-		
	BHP			0.03	0.03	0.03	0.03	-	-	-		
	Sones			5.9	5.6	5.4	5.3	-	-	-		
1650	CFM			351	300	245	190	114	-	-		
	BHP			0.04	0.04	0.04	0.04	0.05	-	-		
	Sones			6.8	6.5	6.4	6.3	6.2	-	-		
SDBD7 1/10 HP 1550 RPM	SDBDe7 1/3 HP 1750 RPM			900	CFM	259	168	-	-	-	-	-
					BHP	0.01	0.02	-	-	-	-	-
					Sones	2.10	1.90	-	-	-	-	-
				1050	CFM	303	227	129	-	-	-	-
					BHP	0.02	0.02	0.02	-	-	-	-
					Sones	3.10	2.70	3.00	-	-	-	-
		1200	CFM	346	281	204	97	-	-	-		
			BHP	0.03	0.03	0.04	0.04	-	-	-		
			Sones	4.40	3.80	3.90	4.20	-	-	-		
		1350	CFM	389	332	269	192	79	-	-		
			BHP	0.04	0.05	0.05	0.05	0.05	-	-		
			Sones	5.50	5.00	5.00	5.20	5.50	-	-		
		1500	CFM	432	382	326	264	191	79	-		
			BHP	0.06	0.06	0.07	0.07	0.07	0.07	-		
			Sones	6.40	6.20	6.20	6.30	6.50	6.70	-		
		1650	CFM	476	429	380	329	266	199	94		
			BHP	0.08	0.08	0.09	0.09	0.09	0.09	0.09		
			Sones	7.30	7.20	7.10	7.20	7.30	7.50	7.70		



S&P USA Ventilation Systems, LLC., Div. of Soler & Palau Ventilation Group, certifies that the Models SDBD shown herein are licensed to bear the AMCA Seal. The ratings shown are based on test and procedures performed in accordance with AMCA Publication 211 and AMCA Publication 311 and comply with the requirement of the AMCA Certified Ratings Program.



(1) Models SDBD6/SDBDe6 and SDBD6C/SDBDe6C have a choke plate. Performance certified is for installation type A-free inlet, free outlet. Performance ratings include the effects of birdscreen in the airstream.

The sound ratings shown are loudness values in fan sones @ 5' (1.5m) in a hemispherical free field calculated per AMCA Standard 301. Values shown are for Installation Type A: free inlet hemispherical sone levels.

Speed (RPM) shown is nominal. Performance is based on actual speed of test.

Fan RPM performances may vary from actual current motor offerings for any given model. See Optimizer2 fan selection software for current motor RPM offerings



Size 8

Motor HP	RPM		Static Pressure in Inches w.g.								
			0	0.125	0.25	0.375	0.5	0.625	0.75	0.875	
SDBD 1/25 HP 1050 RPM	700	CFM	361	187	-	-	-	-	-	-	-
		BHP	0.01	0.01	-	-	-	-	-	-	-
		Sones	2.3	1.5	-	-	-	-	-	-	-
	850	CFM	438	325	-	-	-	-	-	-	-
		BHP	0.01	0.01	-	-	-	-	-	-	-
		Sones	3.5	2.9	-	-	-	-	-	-	-
	1000	CFM	515	424	279	-	-	-	-	-	-
		BHP	0.02	0.02	0.02	-	-	-	-	-	-
		Sones	5	4.8	3.8	-	-	-	-	-	-
	1150	CFM	592	514	421	206	-	-	-	-	-
		BHP	0.03	0.03	0.03	0.03	-	-	-	-	-
		Sones	6.7	6.5	5.6	5	-	-	-	-	-
SDBDe 1/3 HP 1750 RPM	1200	CFM	627	538	432	288	-	-	-	-	
		BHP	0.01	0.02	0.03	0.03	-	-	-	-	
		Sones	6	5.6	5.4	5	-	-	-	-	
	1250	CFM	653	568	470	348	-	-	-	-	
		BHP	0.01	0.02	0.03	0.04	-	-	-	-	
		Sones	6.5	6.1	5.9	5.5	-	-	-	-	
	1300	CFM	679	598	507	396	-	-	-	-	
		BHP	0.01	0.03	0.04	0.04	-	-	-	-	
		Sones	7.1	6.6	6.4	6.1	-	-	-	-	
	1350	CFM	705	627	543	437	284	-	-	-	
		BHP	0.02	0.03	0.04	0.04	0.04	-	-	-	
		Sones	7.6	7.1	6.9	6.6	6.3	-	-	-	
	1400	CFM	731	657	576	476	351	-	-	-	
		BHP	0.02	0.03	0.04	0.05	0.05	-	-	-	
		Sones	8.2	7.7	7.4	7.2	6.8	-	-	-	
	1450	CFM	757	687	609	514	409	-	-	-	
		BHP	0.02	0.04	0.05	0.05	0.06	-	-	-	
		Sones	8.8	8.3	7.9	7.8	7.4	-	-	-	
	1500	CFM	783	716	640	552	456	304	-	-	
		BHP	0.02	0.04	0.05	0.06	0.06	0.05	-	-	
		Sones	9.5	8.9	8.5	8.4	8	7.7	-	-	
	1550	CFM	809	746	672	589	497	373	-	-	
		BHP	0.03	0.04	0.05	0.06	0.07	0.07	-	-	
		Sones	10	9.3	8.9	8.9	8.5	8.2	-	-	
1600	CFM	835	775	702	626	537	434	265	-		
	BHP	0.03	0.04	0.05	0.07	0.07	0.08	0.06	-		
	Sones	10.4	9.8	9.3	9.3	9	8.7	8.4	-		
1650	CFM	862	804	733	662	576	485	343	-		
	BHP	0.03	0.05	0.06	0.08	0.08	0.08	0.07	-		
	Sones	10.9	10.3	9.7	9.7	9.5	9.2	8.9	-		
SDBD 1/4 HP 1625 RPM	1700	CFM	867	814	761	705	630	557	441	-	
		BHP	0.07	0.08	0.09	0.1	0.11	0.11	0.11	-	
		Sones	11	10.8	10.5	10.3	10	9.9	9.9	-	
	1750	CFM	892	842	789	738	667	595	505	297	
		BHP	0.08	0.09	0.1	0.11	0.12	0.12	0.12	0.1	
		Sones	11.5	11.3	11.1	10.8	10.6	10.4	10.4	11	



S&P USA Ventilation Systems, LLC., Div. of Soler & Palau Ventilation Group, certifies that the Models SDBD shown herein are licensed to bear the AMCA Seal. The ratings shown are based on test and procedures performed in accordance with AMCA Publication 211 and AMCA Publication 311 and comply with the requirement of the AMCA Certified Ratings Program.



Performance certified is for installation type A-free inlet, free outlet. Performance ratings include the effects of birdscreen in the airstream.

The sound ratings shown are loudness values in fan sones @ 5' (1.5m) in a hemispherical free field calculated per AMCA Standard 301. Values shown are for Installation Type A: free inlet hemispherical sone levels.

Speed (RPM) shown is nominal. Performance is based on actual speed of test.

Fan RPM performances may vary from actual current motor offerings for any given model. See Optimizer2 fan selection software for current motor RPM offerings



Size 10

Motor HP	RPM		Static Pressure in Inches w.g.											
			0	0.125	0.25	0.375	0.5	0.625	0.75	0.875	1			
SDBD 1/4 HP 1075 RPM	700	CFM	578	398	-	-	-	-	-	-	-	-	-	
		BHP	0.01	0.02	-	-	-	-	-	-	-	-	-	
		Sones	3.4	2.4	-	-	-	-	-	-	-	-	-	
	850	CFM	701	559	-	-	-	-	-	-	-	-	-	
		BHP	0.02	0.03	-	-	-	-	-	-	-	-	-	
		Sones	5	4	-	-	-	-	-	-	-	-	-	
	1000	CFM	825	705	575	-	-	-	-	-	-	-	-	
		BHP	0.04	0.05	0.06	-	-	-	-	-	-	-	-	
		Sones	6.7	5.7	5.4	-	-	-	-	-	-	-	-	
	1150	CFM	949	847	738	607	419	-	-	-	-	-	-	
		BHP	0.06	0.08	0.08	0.09	0.09	-	-	-	-	-	-	
		Sones	8.6	7.6	7.1	7.1	7.1	-	-	-	-	-	-	
	SDBDe 1/3 HP 1750 RPM	1200	CFM	951	857	748	624	458	-	-	-	-	-	-
			BHP	0.07	0.08	0.08	0.09	0.09	-	-	-	-	-	-
			Sones	7.3	6.8	5.9	5.1	5.2	-	-	-	-	-	-
1250		CFM	991	900	796	682	541	-	-	-	-	-	-	
		BHP	0.08	0.08	0.09	0.09	0.1	-	-	-	-	-	-	
		Sones	7.9	7.4	6.6	5.5	5.6	-	-	-	-	-	-	
1300		CFM	1031	944	844	739	613	424	-	-	-	-	-	
		BHP	0.09	0.09	0.1	0.1	0.11	0.11	-	-	-	-	-	
		Sones	8.5	8	7.4	6	6	6.2	-	-	-	-	-	
1350		CFM	1070	987	892	793	677	527	-	-	-	-	-	
		BHP	0.1	0.1	0.11	0.12	0.12	0.12	-	-	-	-	-	
		Sones	9.1	8.6	8.1	6.7	6.4	6.5	-	-	-	-	-	
1400		CFM	1110	1030	939	846	738	609	402	-	-	-	-	
		BHP	0.11	0.12	0.12	0.13	0.13	0.14	0.13	-	-	-	-	
		Sones	9.7	9.2	8.8	7.5	6.8	6.9	7.1	-	-	-	-	
1450	CFM	1150	1072	986	896	796	680	522	-	-	-	-		
	BHP	0.12	0.13	0.14	0.14	0.15	0.15	0.15	-	-	-	-		
	Sones	10.3	9.8	9.4	8.2	7.2	7.3	7.5	-	-	-	-		
1500	CFM	1189	1115	1033	946	852	745	614	398	-	-	-		
	BHP	0.13	0.14	0.15	0.15	0.16	0.17	0.17	0.16	-	-	-		
	Sones	11	10.5	10.1	9.1	7.8	7.8	7.9	8.1	-	-	-		
1550	CFM	1229	1157	1079	994	906	806	691	529	-	-	-		
	BHP	0.15	0.16	0.16	0.17	0.17	0.18	0.19	0.18	-	-	-		
	Sones	11.5	11	10.6	9.8	8.4	8	8.2	8.4	-	-	-		
1600	CFM	1269	1199	1125	1042	959	865	761	628	414	-	-		
	BHP	0.16	0.17	0.18	0.18	0.19	0.2	0.2	0.2	0.19	-	-		
	Sones	12	11.6	11.1	10.5	9.1	8.3	8.4	8.7	8.9	-	-		
1650	CFM	1308	1241	1170	1089	1011	922	824	710	550	-	-		
	BHP	0.18	0.19	0.2	0.2	0.21	0.22	0.22	0.22	0.22	-	-		
	Sones	12.6	12.1	11.7	11.2	9.8	8.6	8.8	9	9.1	-	-		
1700	CFM	1348	1282	1214	1137	1060	977	886	783	653	-	-		
	BHP	0.19	0.2	0.21	0.22	0.22	0.23	0.24	0.24	0.24	-	-		
	Sones	13.1	12.6	12.2	11.8	10.5	9.3	9.1	9.2	9.4	-	-		

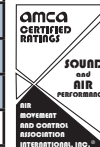

S&P USA Ventilation Systems, LLC., Div. of Soler & Palau Ventilation Group, certifies that the Models SDBD shown herein are licensed to bear the AMCA Seal. The ratings shown are based on test and procedures performed in accordance with AMCA Publication 211 and AMCA Publication 311 and comply with the requirement of the AMCA Certified Ratings Program.



Performance certified is for installation type A-free inlet, free outlet. Performance ratings include the effects of birdscreen in the airstream.

The sound ratings shown are loudness values in fan sones @ 5' (1.5m) in a hemispherical free field calculated per AMCA Standard 301. Values shown are for Installation Type A: free inlet hemispherical sone levels.

Speed (RPM) shown is nominal. Performance is based on actual speed of test.

Fan RPM performances may vary from actual current motor offerings for any given model. See Optimizer2 fan selection software for current motor RPM offerings



MODELS SDBD & SDBDe

DIRECT DRIVE CENTRIFUGAL DOWNBLAST ROOF EXHAUSTERS

Size 12

Motor HP	RPM		Static Pressure in Inches w.g.											
			0	0.125	0.25	0.375	0.5	0.625	0.75	0.875	1	1.25		
SDBD 1/4 HP 1075 RPM	900	CFM	1000	856	673	-	-	-	-	-	-	-	-	-
		BHP	0.06	0.07	0.07	-	-	-	-	-	-	-	-	-
		Sones	6.0	5.4	4.9	-	-	-	-	-	-	-	-	-
	950	CFM	1055	920	756	479	-	-	-	-	-	-	-	-
		BHP	0.07	0.08	0.09	0.09	-	-	-	-	-	-	-	-
		Sones	6.6	6.0	5.5	5.3	-	-	-	-	-	-	-	-
	1000	CFM	1111	984	830	626	-	-	-	-	-	-	-	-
		BHP	0.08	0.09	0.10	0.10	-	-	-	-	-	-	-	-
		Sones	7.2	6.6	6.1	5.9	-	-	-	-	-	-	-	-
	1050	CFM	1167	1047	902	728	-	-	-	-	-	-	-	-
		BHP	0.10	0.11	0.11	0.12	-	-	-	-	-	-	-	-
		Sones	7.8	7.2	6.7	6.4	-	-	-	-	-	-	-	-
	1100	CFM	1222	1110	975	821	564	-	-	-	-	-	-	-
		BHP	0.11	0.12	0.13	0.13	0.13	-	-	-	-	-	-	-
		Sones	8.4	7.9	7.3	7.0	6.9	-	-	-	-	-	-	-
	1150	CFM	1281	1176	1050	909	719	-	-	-	-	-	-	-
		BHP	0.13	0.14	0.15	0.15	0.16	-	-	-	-	-	-	-
		Sones	9.1	8.5	8.0	7.5	7.5	-	-	-	-	-	-	-
SDBD 1/2 HP 1625 RPM	1200	CFM	1331	1223	1108	971	805	524	-	-	-	-	-	
		BHP	0.10	0.12	0.13	0.14	0.14	0.14	-	-	-	-	-	
		Sones	9.0	8.6	8.3	8.0	8.0	8.0	-	-	-	-	-	
	1250	CFM	1386	1284	1174	1047	897	702	-	-	-	-	-	
		BHP	0.11	0.13	0.14	0.15	0.16	0.16	-	-	-	-	-	
		Sones	9.6	9.2	8.9	8.6	8.5	8.6	-	-	-	-	-	
	1300	CFM	1442	1343	1239	1121	983	822	514	-	-	-	-	
		BHP	0.13	0.15	0.16	0.17	0.18	0.18	0.17	-	-	-	-	
		Sones	10.3	9.9	9.6	9.3	9.0	9.1	9.2	-	-	-	-	
	1350	CFM	1497	1403	1302	1193	1065	916	707	-	-	-	-	
		BHP	0.14	0.16	0.18	0.19	0.20	0.20	0.20	-	-	-	-	
		Sones	10.9	10.5	10.2	10.0	9.6	9.7	9.8	-	-	-	-	
	1400	CFM	1553	1462	1365	1263	1143	1007	850	539	-	-	-	
		BHP	0.16	0.18	0.20	0.21	0.22	0.23	0.23	0.21	-	-	-	
		Sones	11.6	11.2	10.9	10.6	10.3	10.3	10.4	10.5	-	-	-	
	1450	CFM	1608	1521	1427	1331	1219	1093	949	735	-	-	-	
		BHP	0.18	0.20	0.22	0.23	0.24	0.25	0.25	0.25	-	-	-	
		Sones	12.3	11.9	11.6	11.3	11.0	10.8	10.9	11.1	-	-	-	
1500	CFM	1664	1580	1489	1398	1293	1175	1043	890	589	-	-		
	BHP	0.20	0.22	0.24	0.25	0.26	0.27	0.28	0.28	0.26	-	-		
	Sones	13.0	12.6	12.3	12.0	11.7	11.5	11.6	11.7	11.8	-	-		
1550	CFM	1719	1638	1551	1464	1365	1254	1132	995	785	-	-		
	BHP	0.22	0.24	0.26	0.28	0.29	0.30	0.31	0.31	0.30	-	-		
	Sones	13.7	13.3	12.9	12.7	12.4	12.1	12.1	12.2	12.3	-	-		
1600	CFM	1774	1696	1612	1529	1435	1331	1217	1089	942	-	-		
	BHP	0.24	0.26	0.28	0.30	0.31	0.32	0.33	0.34	0.34	-	-		
	Sones	14.4	14.0	13.6	13.3	13.0	12.8	12.6	12.7	12.8	-	-		
1650	CFM	1830	1754	1673	1592	1504	1406	1298	1180	1051	-	-		
	BHP	0.26	0.28	0.31	0.33	0.34	0.35	0.36	0.37	0.37	-	-		
	Sones	15.1	14.7	14.3	14.0	13.7	13.4	13.2	13.2	13.3	-	-		
1700	CFM	1885	1812	1734	1653	1572	1479	1377	1267	1144	753	-		
	BHP	0.29	0.31	0.33	0.35	0.37	0.38	0.39	0.40	0.40	0.39	-		
	Sones	15.9	15.4	15.0	14.7	14.4	14.1	13.8	13.7	13.9	14.1	-		

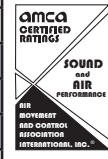

S&P USA Ventilation Systems, LLC., Div. of Soler & Palau Ventilation Group, certifies that the Models SDBD shown herein are licensed to bear the AMCA Seal. The ratings shown are based on test and procedures performed in accordance with AMCA Publication 211 and AMCA Publication 311 and comply with the requirement of the AMCA Certified Ratings Program.



Performance certified is for installation type A-free inlet, free outlet. Performance ratings include the effects of birdscreen in the airstream.

The sound ratings shown are loudness values in fan sones @ 5' (1.5m) in a hemispherical free field calculated per AMCA Standard 301. Values shown are for Installation Type A: free inlet hemispherical sone levels.

Speed (RPM) shown is nominal. Performance is based on actual speed of test.

Fan RPM performances may vary from actual current motor offerings for any given model. See Optimizer2 fan selection software for current motor RPM offerings



Size 14

Motor HP		RPM	Static Pressure in Inches w.g.												
			0	0.125	0.25	0.375	0.5	0.625	0.75	0.875	1	1.25	1.5		
SDBD 1/4 HP 1075 RPM	SDBDe 1/2 HP 1150 RPM	750	CFM	1511	1269	942	-	-	-	-	-	-	-	-	-
			BHP	0.07	0.08	0.08	-	-	-	-	-	-	-	-	-
			Sones	6.5	5.7	4.6	-	-	-	-	-	-	-	-	-
		800	CFM	1612	1387	1103	-	-	-	-	-	-	-	-	-
			BHP	0.08	0.09	0.10	-	-	-	-	-	-	-	-	-
			Sones	7.3	6.5	5.3	-	-	-	-	-	-	-	-	-
		850	CFM	1712	1503	1252	892	-	-	-	-	-	-	-	-
			BHP	0.10	0.11	0.12	0.12	-	-	-	-	-	-	-	-
			Sones	8.2	7.4	6.2	5.7	-	-	-	-	-	-	-	-
		900	CFM	1813	1617	1393	1093	-	-	-	-	-	-	-	-
			BHP	0.12	0.13	0.14	0.15	-	-	-	-	-	-	-	-
			Sones	9.0	8.3	7.2	6.5	-	-	-	-	-	-	-	-
		950	CFM	1914	1731	1524	1256	858	-	-	-	-	-	-	-
			BHP	0.14	0.15	0.17	0.17	0.16	-	-	-	-	-	-	-
			Sones	9.9	9.2	8.2	7.2	7.0	-	-	-	-	-	-	-
		1000	CFM	2015	1845	1649	1412	1116	-	-	-	-	-	-	-
			BHP	0.16	0.18	0.19	0.20	0.20	-	-	-	-	-	-	-
			Sones	11.0	10.2	9.4	8.0	7.8	-	-	-	-	-	-	-
		1050	CFM	2115	1958	1769	1560	1298	884	-	-	-	-	-	-
			BHP	0.18	0.20	0.22	0.23	0.23	0.22	-	-	-	-	-	-
			Sones	12.0	11.3	10.5	9.1	8.6	8.4	-	-	-	-	-	-
		1100	CFM	2196	2047	1864	1673	1428	1115	-	-	-	-	-	-
			BHP	0.21	0.23	0.24	0.25	0.26	0.25	-	-	-	-	-	-
			Sones	13.0	12.3	11.6	10.2	9.4	9.2	-	-	-	-	-	-
SDBD 3/4 HP 1650 RPM	SDBDe 1 HP 1750 RPM	1,150	CFM	2285	2164	2042	1894	1732	1562	1306	-	-	-	-	
			BHP	0.25	0.28	0.31	0.33	0.36	0.37	0.37	-	-	-	-	
			Sones	12.2	11.6	11.2	10.7	10.2	9.7	10.4	-	-	-	-	
		1,200	CFM	2384	2268	2152	2018	1862	1708	1508	1207	-	-	-	
			BHP	0.28	0.31	0.34	0.37	0.40	0.42	0.43	0.40	-	-	-	
			Sones	13.1	12.5	12.1	11.7	11.2	10.6	10.8	11.7	-	-	-	
		1,250	CFM	2484	2372	2262	2138	1990	1842	1680	1437	-	-	-	
			BHP	0.32	0.35	0.38	0.41	0.44	0.46	0.48	0.47	-	-	-	
			Sones	13.8	13.3	13.0	12.7	12.2	11.6	11.1	12.0	-	-	-	
		1,300	CFM	2583	2476	2370	2255	2117	1974	1830	1643	1393	-	-	
			BHP	0.36	0.39	0.42	0.46	0.49	0.51	0.53	0.54	0.52	-	-	
			Sones	14.7	14.2	14.0	13.7	13.2	12.6	12.2	12.3	13.2	-	-	
		1,350	CFM	2682	2579	2477	2369	2242	2104	1967	1814	1597	-	-	
			BHP	0.40	0.44	0.47	0.50	0.54	0.57	0.59	0.60	0.60	-	-	
			Sones	15.6	15.2	14.9	14.7	14.2	13.7	13.1	12.7	13.5	-	-	
		1,400	CFM	2782	2682	2584	2482	2365	2231	2099	1965	1794	-	-	
			BHP	0.45	0.48	0.52	0.55	0.59	0.62	0.65	0.66	0.68	-	-	
			Sones	16.8	16.2	15.9	15.7	15.4	14.8	14.2	13.7	13.8	-	-	
		1,450	CFM	2881	2785	2690	2593	2485	2358	2230	2103	1961	1540	-	
			BHP	0.50	0.53	0.57	0.61	0.64	0.68	0.71	0.73	0.75	0.72	-	
			Sones	17.9	17.3	17.0	16.7	16.5	15.9	15.4	14.9	14.3	16.0	-	
		1,500	CFM	2980	2887	2796	2703	2601	2483	2358	2235	2110	1744	-	
			BHP	0.55	0.59	0.63	0.66	0.70	0.74	0.77	0.80	0.82	0.82	-	
			Sones	19.0	18.4	18.0	17.8	17.6	17.1	16.5	16.0	15.5	16.3	-	
1,550	CFM	3080	2990	2901	2812	2716	2607	2485	2367	2247	1950	-			
	BHP	0.61	0.65	0.69	0.72	0.76	0.80	0.84	0.87	0.89	0.92	-			
	Sones	20.2	19.6	19.0	18.7	18.4	18.0	17.5	16.9	16.4	16.4	-			
1,600	CFM	3179	3092	3006	2920	2829	2728	2612	2496	2380	2125	1744			
	BHP	0.67	0.71	0.75	0.79	0.83	0.87	0.91	0.94	0.97	1.01	0.98			
	Sones	21.4	20.8	20.2	19.6	19.4	19.2	18.6	18.0	17.5	16.7	18.4			
1,650	CFM	3278	3194	3110	3027	2940	2846	2737	2623	2512	2280	1941			
	BHP	0.73	0.78	0.82	0.86	0.90	0.94	0.98	1.02	1.05	1.09	1.10			
	Sones	22.6	21.9	21.3	20.8	20.3	20.1	19.5	19.0	18.4	17.4	18.5			
1,725	CFM	3507	3432	3345	3245	3137	3025	2911	2802	2683	2401	2014			
	BHP	0.64	0.67	0.69	0.72	0.75	0.78	0.81	0.84	0.86	0.89	0.88			
	Sones	23.1	22.5	21.9	21.3	20.8	20.3	19.8	19.3	18.8	18.1	17.6			



S&P USA Ventilation Systems, LLC., Div. of Soler & Palau Ventilation Group, certifies that the Models SDBD shown herein are licensed to bear the AMCA Seal. The ratings shown are based on test and procedures performed in accordance with AMCA Publication 211 and AMCA Publication 311 and comply with the requirement of the AMCA Certified Ratings Program.



STANDARD 705

Performance certified is for installation type A-free inlet, free outlet. Performance ratings include the effects of birdscreen in the airstream.

The sound ratings shown are loudness values in fan sones @ 5' (1.5m) in a hemispherical free field calculated per AMCA Standard 301. Values shown are for Installation Type A: free inlet hemispherical sone levels.

Speed (RPM) shown is nominal. Performance is based on actual speed of test.

Fan RPM performances may vary from actual current motor offerings for any given model. See Optisizer2 fan selection software for current motor RPM offerings.

Numbers shown in bold font are only achievable by the SDBDe 1 HP model with EC motor.



Size 15

Motor HP	RPM		Static Pressure in Inches w.g.													
			0	0.125	0.25	0.375	0.5	0.625	0.75	0.875	1	1.25	1.5	1.75		
SDBD 1/2 HP 1150 RPM	750	CFM	1748	1556	1282	779	-	-	-	-	-	-	-	-	-	-
		BHP	0.08	0.09	0.10	0.10	-	-	-	-	-	-	-	-	-	-
		Sones	7.4	6.9	6.2	5.6	-	-	-	-	-	-	-	-	-	-
	800	CFM	1865	1688	1445	1140	-	-	-	-	-	-	-	-	-	-
		BHP	0.10	0.11	0.12	0.13	-	-	-	-	-	-	-	-	-	-
		Sones	8.3	7.7	7.1	6.4	-	-	-	-	-	-	-	-	-	-
	850	CFM	1981	1816	1601	1334	-	-	-	-	-	-	-	-	-	-
		BHP	0.11	0.13	0.15	0.16	-	-	-	-	-	-	-	-	-	-
		Sones	9.2	8.6	8.2	7.3	-	-	-	-	-	-	-	-	-	-
	900	CFM	2098	1943	1751	1508	1199	-	-	-	-	-	-	-	-	-
		BHP	0.14	0.16	0.17	0.18	0.19	-	-	-	-	-	-	-	-	-
		Sones	10.1	9.5	9.3	8.3	7.8	-	-	-	-	-	-	-	-	-
	950	CFM	2214	2068	1896	1674	1419	-	-	-	-	-	-	-	-	-
		BHP	0.16	0.18	0.20	0.21	0.22	-	-	-	-	-	-	-	-	-
		Sones	11.1	10.5	10.3	9.5	8.6	-	-	-	-	-	-	-	-	-
	1000	CFM	2331	2192	2035	1833	1606	1301	-	-	-	-	-	-	-	-
		BHP	0.19	0.21	0.23	0.24	0.25	0.25	-	-	-	-	-	-	-	-
		Sones	12.2	11.5	11.3	10.7	9.8	9.4	-	-	-	-	-	-	-	-
1050	CFM	2447	2315	2172	1988	1778	1537	-	-	-	-	-	-	-	-	
	BHP	0.21	0.24	0.26	0.27	0.29	0.30	-	-	-	-	-	-	-	-	
	Sones	13.2	12.6	12.3	11.9	11.0	10.2	-	-	-	-	-	-	-	-	
1100	CFM	2564	2438	2305	2138	1943	1732	1454	-	-	-	-	-	-	-	
	BHP	0.25	0.27	0.29	0.31	0.33	0.34	0.34	-	-	-	-	-	-	-	
	Sones	14.4	13.6	13.4	13.2	12.3	11.5	11.1	-	-	-	-	-	-	-	
1150	CFM	2685	2565	2440	2289	2109	1913	1690	1260	-	-	-	-	-	-	
	BHP	0.28	0.31	0.33	0.35	0.37	0.38	0.39	0.38	-	-	-	-	-	-	
	Sones	15.6	14.8	14.6	14.4	13.6	12.7	12.0	12.0	-	-	-	-	-	-	
SDBD 3/4 HP 1650 RPM	1450	CFM	2774	2665	2547	2439	2321	2187	2058	1912	1757	1657	-	-	-	
		BHP	0.44	0.47	0.50	0.52	0.55	0.58	0.60	0.61	0.62	0.63	-	-	-	
		Sones	18.9	18.3	17.7	17.2	16.7	16.2	15.8	15.9	16.1	16.6	-	-	-	
	1500	CFM	2869	2764	2651	2545	2436	2307	2183	2050	1900	1700	-	-	-	
		BHP	0.49	0.52	0.55	0.57	0.60	0.63	0.65	0.67	0.68	0.69	-	-	-	
		Sones	20.1	19.4	18.8	18.2	17.7	17.3	16.9	16.8	17.0	17.4	-	-	-	
	1550	CFM	2965	2863	2754	2649	2549	2427	2304	2182	2044	1744	1517	-	-	
		BHP	0.54	0.57	0.60	0.63	0.66	0.69	0.71	0.73	0.75	0.77	0.76	-	-	
		Sones	21.0	20.4	19.8	19.2	18.6	18.1	17.7	17.4	17.5	17.9	18.4	-	-	
	1600	CFM	3061	2962	2857	2754	2657	2546	2424	-	-	-	-	-	-	
		BHP	0.59	0.63	0.66	0.68	0.72	0.75	0.77	-	-	-	-	-	-	
		Sones	21.9	21.3	20.8	20.2	19.7	19.2	18.7	-	-	-	-	-	-	
1650	CFM	3156	3061	2960	2857	2765	-	-	-	-	-	-	-	-		
	BHP	0.65	0.68	0.72	0.74	0.78	-	-	-	-	-	-	-	-		
	Sones	22.8	22.2	21.7	21.1	20.6	-	-	-	-	-	-	-	-		
SDBD 1-1/2 HP 1725 RPM	1750	CFM	4083	4005	3920	3825	3723	3622	3523	3421	3308	3068	2810	2508		
		BHP	0.82	0.85	0.89	0.92	0.96	0.99	1.03	1.06	1.09	1.15	1.19	1.22		
		Sones	22.2	21.9	21.5	21.1	20.7	20.5	20.6	20.6	20.6	20.7	20.9	21.1		

Performance certified is for installation type A-free inlet, free outlet. Performance ratings include the effects of birdscreen in the airstream.

The sound ratings shown are loudness values in fan sones @ 5' (1.5m) in a hemispherical free field calculated per AMCA Standard 301. Values shown are for Installation Type A: free inlet hemispherical sone levels.

Speed (RPM) shown is nominal. Performance is based on actual speed of test.

Fan RPM performances may vary from actual current motor offerings for any given model. See Optisizer2 fan selection software for current motor RPM offerings



S&P USA Ventilation Systems, LLC., Div. of Soler & Palau Ventilation Group, certifies that the Models SDBD shown herein are licensed to bear the AMCA Seal. The ratings shown are based on test and procedures performed in accordance with AMCA Publication 211 and AMCA Publication 311 and comply with the requirement of the AMCA Certified Ratings Program.





Size 16

Motor HP		RPM		Static Pressure in Inches w.g.												
				0	0.125	0.25	0.375	0.5	0.625	0.75	0.875	1	1.25	1.5	1.75	
SDBD 1/2 HP 1150	SDBDe 1 HP 1150 RPM	750	CFM	2172	1945	1680	1317	-	-	-	-	-	-	-	-	-
			BHP	0.11	0.13	0.13	0.14	-	-	-	-	-	-	-	-	-
			Sones	8.6	8.1	7.4	6.7	-	-	-	-	-	-	-	-	
		800	CFM	2316	2105	1864	1555	-	-	-	-	-	-	-	-	-
			BHP	0.13	0.15	0.16	0.17	-	-	-	-	-	-	-	-	
			Sones	9.6	9.1	8.5	7.9	-	-	-	-	-	-	-		
		850	CFM	2461	2263	2039	1776	1424	-	-	-	-	-	-	-	
			BHP	0.16	0.18	0.19	0.20	0.20	-	-	-	-	-	-		
			Sones	10.6	10.1	9.6	9.1	8.3	-	-	-	-	-	-		
		900	CFM	2606	2419	2212	1984	1682	-	-	-	-	-	-		
			BHP	0.19	0.21	0.23	0.23	0.24	-	-	-	-	-	-		
			Sones	11.7	11.2	10.7	10.3	9.5	-	-	-	-	-			
		950	CFM	2751	2574	2383	2175	1913	1590	-	-	-	-	-		
			BHP	0.22	0.24	0.26	0.27	0.28	0.28	-	-	-	-	-		
			Sones	12.8	12.4	12.0	11.4	11.0	10.1	-	-	-	-			
		1000	CFM	2896	2727	2551	2354	2129	1849	-	-	-	-	-		
			BHP	0.25	0.28	0.30	0.32	0.33	0.33	-	-	-	-	-		
			Sones	13.9	13.5	13.2	12.7	12.3	11.5	-	-	-	-			
1050	CFM	3040	2880	2716	2527	2334	2085	1802	-	-	-	-				
	BHP	0.29	0.32	0.34	0.36	0.37	0.38	0.38	-	-	-	-				
	Sones	15.1	14.7	14.4	14.0	13.6	13.1	12.1	-	-	-					
1100	CFM	3185	3032	2877	2701	2523	2304	2048	-	-	-	-				
	BHP	0.34	0.36	0.39	0.41	0.42	0.44	0.44	-	-	-	-				
	Sones	16.4	16.0	15.7	15.3	14.9	14.6	13.7	-	-	-					
1150	CFM	3298	3150	3002	2835	2663	2468	2234	1975	-	-	-				
	BHP	0.37	0.40	0.43	0.45	0.47	0.48	0.49	0.49	-	-	-				
	Sones	17.7	17.3	17.0	16.6	16.3	15.9	15.4	14.3	-	-					
SDBD 1-1/2 HP 1725 RPM	1750	CFM	4984	4896	4804	4705	4601	4493	4383	4271	4155	3911	3636	3305		
		BHP	1.16	1.20	1.24	1.28	1.32	1.36	1.39	1.42	1.45	1.53	1.59	1.63		
		Sones	31.7	31.4	31.1	30.9	30.7	30.7	30.4	29.8	29.2	28.1	27.2	26.7		

Performance certified is for installation type A-free inlet, free outlet. Performance ratings include the effects of birdscreen in the airstream. The sound ratings shown are loudness values in fan sones @ 5' (1.5m) in a hemispherical free field calculated per AMCA Standard 301. Values shown are for Installation Type A: free inlet hemispherical sone levels.

Speed (RPM) shown is nominal. Performance is based on actual speed of test.

Fan RPM performances may vary from actual current motor offerings for any given model. See Optimizer2 fan selection software for current motor RPM offerings



S&P USA Ventilation Systems, LLC., Div. of Soler & Palau Ventilation Group, certifies that the Models SDBD shown herein are licensed to bear the AMCA Seal. The ratings shown are based on test and procedures performed in accordance with AMCA Publication 211 and AMCA Publication 311 and comply with the requirement of the AMCA Certified Ratings Program.

