

# MODEL TH-MIXVENT

(Rooftop Fan For High Air Flow to Pressure Ratio Applications Minimum Space)



The World's Leading Producer of  
**Air Movement Products**  
 6393 Powers Avenue  
 Jacksonville, Florida 32217-2298  
 P: 800.961.7370 F: 800.961.7379  
 www.solerpalau-usa.com

## Dimensions inches/mm

Model	A	B	C	D	E	F	G	H	I
TH-250	21 1/2	18	17 1/8	9 3/4	13	1/2	13/16	14 5/8	1 5/8
	546	457	435	248	330	12	20	372	42
TH-315	28 15/16	21 7/16	22 1/16	12 5/16	17 11/16	1/2	13/16	17 11/16	1 15/16
	735	544	560	312	450	12	20	450	50

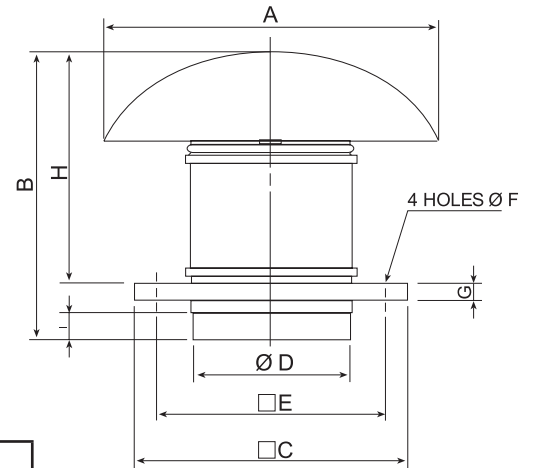

FAN DATA					
Fan No.	Qty.	Model No.	CFM	SP	RPM

For more information contact us at [www.solerpalau-usa.com](http://www.solerpalau-usa.com) or 1.800.961.7370 for additional submittal drawings.

MOTOR DATA					
AMPS	RPM	VOLTS	PH	HZ	ENCLOSURE

Soler & Palau will not be responsible for fabrication changes or errors resulting from customer use of a non-current submittal drawing.

ACCESSORIES	1	2	3	4	5	REMARKS

PROJECT: \_\_\_\_\_ CONTRACTOR: \_\_\_\_\_  
 LOCATION: \_\_\_\_\_ REVISION DATE: \_\_\_\_\_  
 FORM NO.: \_\_\_\_\_ SUBMITTED BY: \_\_\_\_\_ DATE: \_\_\_\_\_  
 ENGINEER: \_\_\_\_\_ APPROVED BY: \_\_\_\_\_ DATE: \_\_\_\_\_

