

The World's Leading Producer of Air Movement Products

Bathroom Exhaust

Bathroom Exhaust...

SOLVED!



If the strongest, quietest, bathroom exhaust system is what you seek...look no further. S&P offers the perfect solution with the most options. The popular and exclusive TD series bathroom exhaust kits (for single or dual venting points) the ultra powerful PV series (also, in single or dual vents) for long or complicated duct runs. All S&P bath kits offer remotely mounted fans featuring a powerful fan mounted in the attic (away from the living space). The result is a "Turbo" powered fan (much stronger than generally associated with bathroom exhaust) and yet a peacefully quiet operation. You also have the choice of the SWF sidewall series fan, featuring the powerful PV motor, when attic space or easy indoor access is difficult or not suitable for traditional in-line mounting.



Inline Fans For Bathroom Exhaust

TD-MIXVENT SERIES



The TD Series is the perfect bathroom ventilator for most typical installations. These units handle a significant amount of pressure (associated with most jobs) and unsurpassed air movement, with a minimum of space required. Suitable for 4" through 12" (kits available in 4" and 6") round duct applications, from 97-1050 CFM (cubic feet of air per minute). Strong, quiet, easy to install (in even the tightest spaces) and years of trouble free operation.

PV-POWERVENT SERIES



The PV Series is the perfect solution for installations that require long or complicated duct runs. These sturdy units are available for 4" through 12" round duct installations: from 108-942 CFM. The centrifugal blade designs are able to overcome extreme resistance for even the most challenging installations. The PV offers the same totally enclosed motors as the popular TD series which ensure long, trouble free life. The PV series is the right choice for more difficult installations.

Sidewall Fans For Bathroom Exhaust

SWF-SIDEWALL SERIES



The SWF Series' outdoor rated exterior housing provides easy access from the outside of a building or dwelling. This makes the SWF a great solution for installations where attic space or easy indoor access is difficult and not suitable for traditional PV style in-line mounting. The Sidewall Fan Series (SWF) of direct drive centrifugal ventilation fans consists of five model sizes: 4" through 8". All models are designed for direct connection in-line with standard diameter round ducting. Airflow performance values range from 119-416 CFM.

How to Size Your Bathroom Ventilation System

Bathroom Exhaust Advantages

We spend hours upon hours in our bathrooms; why not make them as comfortable as possible. No more loud noisy fans that instantly alert you the moment you hit the switch. S&P offers a range of inline and sidewall fans to fit exactly what you need that offer several advantages over traditional bathroom fans. Our remote mounted fans are powerful enough to vent multiple areas with one unit (dv kits) for today's larger bathrooms. Multiple bathrooms with one unit is also possible. The remote mounting feature, allows peace and quiet in the living space, thus reducing the sound level of a generally noisy fan. S&P remote fans also offer extended duty times, low maintenance and help to reduce moisture, which decreases the likelihood of mold or mildew. They do not detract from the homes aesthetics, unlike some unsightly roof mounted units. S&P remote fans are the clear choice for the strongest, quietest installation.

The following recommendations follow the Home Ventilating Institute (HVI) guidelines.



FAN SIZING FOR BATHROOMS UNDER 100 Sq. Ft.

The standard rule for bathrooms 100 square feet or smaller is one CFM per square foot of the bathroom. To find the square footage multiply the length of the bathroom by the width.

10' x 10' bathroom = 100 square feet.

You will need a 100 CFM fan for this bathroom.

FAN SIZING FOR BATHROOMS OVER 100 Sq. Ft.

Ventilation for baths over 100 square feet is calculated based on the fixtures in the bathroom. Allow 50 CFM for each standard toilet, shower, steam shower or tub. Whirlpool, garden and hot tubs are calculated at 100 CFM each. Add the CFM for all fixtures and you'll have the total CFM required for the bathroom.

Step 1 Calculate Bathroom Size: 20' x 10' Bathroom = 200 square feet

Step 2 1 Toilet + 1 Shower + 1 Tub = 150 CFM

Result **You will need a 150 CFM fan for this bathroom.**

For the most effective bathroom ventilation, HVI recommends eight air changes per hour. Fans should be installed as close to the shower as possible and, if marked as suitable for this location, directly over it to capture the moisture as directly as possible. Your fan should have a control that will allow the fan to run at least 20 to 30 minutes after each shower.

An enclosed toilet should have its own exhaust fan. Fans should be located over the shower or tub. Bathroom doors need to have at least 3/4" clearance to the finished floor to allow entry of makeup air. Using a timer or other control ensures that ventilation continues for a minimum of 20 minutes after use of the bathroom.

For steam showers, we recommend a separate fan in the steam room that you can turn on after use. Bathroom (continuous ventilation) should be available on a continuous basis at a minimum of 20 CFM in lieu of an intermittent 50 CFM fan.



TD - MIXVENT

Technical Specifications

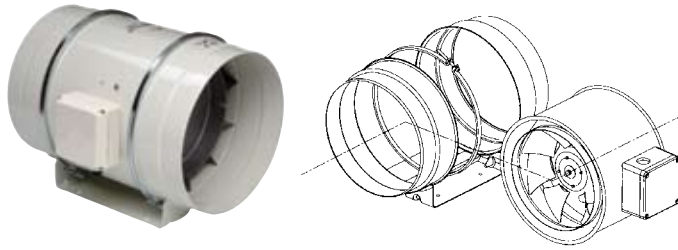

Warranty

Five (5) year limited warranty.

Range

The TD-MIXVENT series consists of eight (8) nominal sized in-line fans. All models are specifically designed for direct connection in-line with industry standard diameter round ducting.

Construction

The TD-MIXVENT models 100, 100x, 125, 150, 200 and 200x are manufactured in tough reinforced plastic, models 250 and 315 have a metal casing and are finished in a tough epoxy-polyester paint coating. The TD fan duct connection flanges are manufactured from reinforced plastic, except for models 200, 200x, 250 and 315 which are constructed from epoxy-polyester coated metal.

Impellers

The impeller blades for models 100, 100x, 125 and 150 and 200x are molded in tough ABS plastic. Models 200, 250 and 315 are metal.

Motors

Models 100, 100x and 125 :

Single-phase, 120V 60Hz, shaded pole induction asynchronous motor in die cast aluminum. All motors include direct two speed connection and are also suitable for voltage speed control.

- Class II electrical insulation (model 100) & Class I (models 100x and 125)
- IP 44 Protection
- Class B Motor Insulation
- Safety auto reset Thermal Overload Protection (fuse type)
- Self-lubricating sleeve bearings.
- Suitable for working airstreams up to 104° F (40°C).

Models 150, 200, 200x, 250 and 315:

- Single-phase induction asynchronous motor, with permanent capacitor and external rotor constructed of die cast aluminum. All models include direct two speed connection and are also suitable for voltage speed control.
- Class I electrical insulation
- IP 44 Protection
- Thermal Overload Protection
- Class B Motor Insulation
- Sealed For Life, ball bearings
- Suitable for working airstreams up to 140° F (60°C).



IMPORTANT: If venting in an non-insulated attic space, or in a cold climate, insulated flexible duct is strongly recommended for condensation issues.

Sound

Fan sound levels are measured in sones. At this time there are no sone level test standards available through HVI due to the fact that remote mounted fan noise levels are in proportion to the following: type of duct, length of duct, fan distance from the intake source and other miscellaneous factors. However it is generally accepted that remote mounted venting is usually quieter than standard (in room) venting.



Soler & Palau USA certifies that the TD range shown herein is licensed to bear the AMCA Seal. The ratings shown are based on tests and procedures performed in accordance with AMCA Publication 211 and comply with the requirements of the AMCA Certified Ratings Program.



The TD-MIXVENT Series fans are California Title 24 compliant and meet ASHRAE 62.2 when installed with 3 way switch and remotely mounted speed control.

PV-POWERVENT

Technical Specifications



All twelve PV model sizes (PV 100, 100x, 125, 125x, 150, 150x, 200, 200x, 250, 250x, 315 & 315x) include the following specifications:

Warranty

Five (5) year limited warranty.

Casing

- Manufactured from high grade pressed galvanized steel, with black baked enamel coating.
- Extra long inlet and discharge collars make installation quick and trouble free.
- Supplied with a strong galvanized steel mounting bracket.
- Supplied with a remote mounting, prewired wiring junction box.

Wheel / Impeller

- Backward curved centrifugal type constructed of metal.
- Factory matched to an external rotor motor and dynamically balanced to eliminate vibration.

Accessories

A wide range of accessories is available to complete the most demanding installation. See pages 8 & 10.

Motor

- Totally enclosed permanent split capacitor start and run external rotor motors.
- 115V 60Hz (single phase) electrical connection.
- Permanently sealed, self lubricating precision ball bearings.
- Safety Thermal Overload Protection Cut-Out (Automatic Reset Type).
- All Models are suitable for working airstreams up to 140° F

Code Approval

- All models have been independently safety tested by Underwriters Laboratories, Inc. and are UL and cUL Listed.
- Independently safety tested by Intertek Laboratories, and are ETL Listed.
- Independently tested for Airflow Performance. The PV range is licensed to bear the AMCA seal for Air Performance.
- The PV product range is certified by the Home Ventilating Institute (HVI) for Air Performance.
- PV 150x and larger ENERGY STAR® qualified.



Sound

Fan sound levels are measured in sones. At this time there are no sone level test standards available through HVI due to the fact that remote mounted fan noise levels are in proportion to the following: type of duct, length of duct, fan distance from the intake source and other miscellaneous factors. However it is generally accepted that remote mounted venting is usually quieter than standard (in room) venting.



Soler & Palau USA certifies that the PV range shown herein is licensed to bear the AMCA Seal. The ratings shown are based on tests and procedures performed in accordance with AMCA Publication 211 and comply with the requirements of the AMCA Certified Ratings Program.



*PV 150x and larger ENERGY STAR® qualified.



The PV-POWERVENT Series fans are California Title 24 compliant and meet ASHRAE 62.2 when installed with 3 way switch and remotely mounted speed control.

SWF-SIDEWALL

Technical Specifications

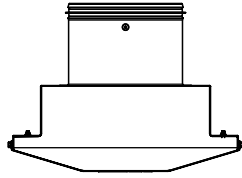

All five SWF models sizes (SWF 100, 100x, 150, 150x & 200) include the following specifications:

Warranty

Five (5) year limited warranty.

Casing

- Manufactured from high grade pressed galvanized steel, with baked enamel coating.
- Removable top for easy access to motor for cleaning or inspection.
- Large grill opening for easy passing of lint and other potentially clogging materials.
- Includes prewired terminal box.

Wheel/Impeller

- Backward curved centrifugal type.
- Factory matched to an external rotor motor and dynamically balanced to eliminate vibration.

Accessories

- A wide range of accessories is available to complete the most demanding installation.

Motors

- Totally enclosed permanent split capacity start and run external rotor motors.
- 115V 60Hz (single phase) electrical connection.
- Permanently sealed, self lubricating precision ball bearings.
- Safety Thermal Overload Protection Cut-Out (Automatic Reset Type).
- All models are suitable for working airstreams up to 140°F.

Code Approval

- All models have been independently safety tested by Underwriters Laboratories, Inc. and are UL and cUL listed.



Sound

Fan sound levels are measured in sones. At this time there are no sone level test standards available through HVI due to the fact that remote mounted fan noise levels are in proportion to the following: type of duct, length of duct, fan distance from the intake source and other miscellaneous factors. However it is generally accepted that remote mounted venting is usually quieter than standard (in room) venting.



The SWF-SIDEWALL Series fans are California Title 24 compliant and meet ASHRAE 62.2 when installed with 3 way switch and remotely mounted speed control.

TD-MIXVENT SERIES

Dimensional Data

Dimensions (inches/mm)

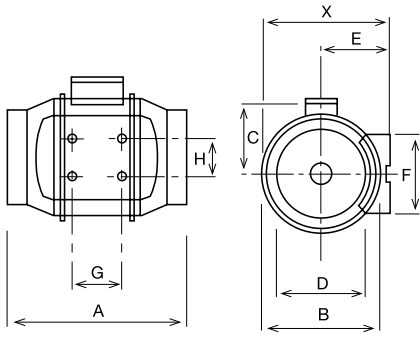

Model	X	A	B	C	D	E	F	G	H
TD-100	5 15/16 151	9 1/8 232	5 7/16 138	3 3/4 96	3 7/8 98	3 1/4 82	3 3/4 95	1 7/8 48	2 1/16 52
TD-100x	7 3/8 188	11 15/16 303	6 15/16 176	4 1/2 115	3 13/16 97	3 15/16 100	3 9/16 90	3 1/8 80	2 3/8 60
TD-125	7 3/8 188	10 3/16 258	6 15/16 176	4 1/2 115	4 13/16 123	3 15/16 100	3 9/16 90	3 1/8 80	2 3/8 60
TD-150	8 3/8 212	11 5/8 295	7 7/8 200	5 127	5 13/16 147	4 7/16 112	5 1/8 130	3 1/8 80	2 3/8 60
TD-200	9 3/16 233	11 7/8 302	8 9/16 217	5 9/16 141	7 13/16 198	4 7/8 124	5 1/2 140	3 15/16 100	3 11/16 94
TD-200x	9 3/16 233	11 7/8 302	8 9/16 217	5 9/16 141	7 13/16 198	4 7/8 124	5 1/2 140	3 15/16 100	3 11/16 94
TD-250	11 7/16 291	15 3/16 386	10 11/16 272	7 9/16 192	9 3/4 248	6 1/8 155	6 5/8 168	5 11/16 145	5 1/2 140
TD-315	14 356	17 11/16 450	13 1/4 336	8 13/16 224	12 5/16 312	7 3/8 188	8 1/4 210	7 3/16 182	7 178

PV-POWERVENT SERIES

Dimensional Data

Dimensions (inches/mm)

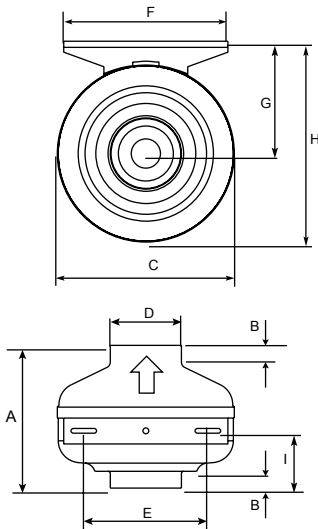

Model	A	B	C	D	E	F	G	H	I	Weight lbs(kgs)
PV-100	7 5/8 194	1 25	9 1/2 241	3 7/8 98	6 11/16 170	8 7/8 225	6 1/16 154	10 13/16 275	3 1/4 83	7 3.0
PV-100x	7 5/8 194	1 25	9 1/2 241	3 7/8 98	6 11/16 170	8 7/8 225	6 1/16 154	10 13/16 275	3 1/4 83	7 3.0
PV-125	7 5/8 194	1 25	9 1/2 241	4 7/8 124	6 11/16 170	8 7/8 225	6 1/16 154	10 13/16 275	3 7/16 87	7 3.0
PV-125x	7 5/8 194	1 25	9 1/2 241	4 7/8 124	6 11/16 170	8 7/8 225	6 1/16 154	10 13/16 275	3 7/16 87	7 3.0
PV-150	8 1/2 216	1 25	13 1/8 333	5 7/8 149	6 11/16 170	8 7/8 225	7 7/8 200	14 3/8 365	3 76	11 5.0
PV-150x	8 1/2 216	1 25	13 1/8 333	5 7/8 149	6 11/16 170	8 7/8 225	7 7/8 200	14 3/8 365	3 76	11 5.0
PV-200	8 1/2 216	1 25	13 1/8 333	7 7/8 200	6 11/16 170	8 7/8 225	7 7/8 200	14 3/8 365	3 11/16 94	11 5.0
PV-200x	8 1/2 216	1 25	13 1/8 333	7 7/8 200	6 11/16 170	8 7/8 225	7 7/8 200	14 3/8 365	3 11/16 94	11 5.0
PV-250	8 1/2 216	1 25	13 1/8 333	9 7/8 251	6 11/16 170	8 7/8 225	7 7/8 200	14 3/8 365	3 1/4 83	13 6.0
PV-250x	8 1/2 216	1 25	13 1/8 333	9 7/8 251	6 11/16 170	8 7/8 225	7 7/8 200	14 3/8 365	3 1/4 83	13 6.0
PV-315	9 1/16 230	1 25	15 13/16 401	12 5/16 312	6 11/16 170	8 7/8 225	9 3/16 234	17 1/8 435	3 1/2 89	21 10.0
PV-315x	9 1/16 230	1 25	15 13/16 401	12 5/16 312	6 11/16 170	8 7/8 225	9 3/16 234	17 1/8 435	3 1/2 89	21 10.0

SWF-SIDEWALL SERIES

Dimensional Data

Dimensions (inches/mm)

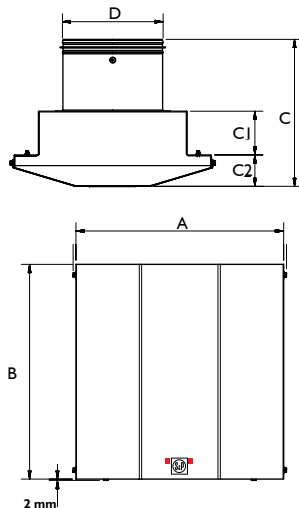

Model	A	B	C	C1	C2	D
SWF-100	13 1/4 337	13 1/4 337	9 228	3 76	2 7/16 62	4 100
SWF-100x	13 1/4 337	13 1/4 337	9 228	3 76	2 7/16 62	4 100
SWF-150	15 1/2 394	13 1/4 337	10 3/16 256	3 76	2 7/16 62	6 150
SWF-150x	15 1/2 394	16 1/16 408	10 254	3 3/16 81	2 7/16 62	6 150
SWF-200	15 1/2 394	16 1/16 408	11 7/16 290	3 3/8 87	2 7/16 62	8 200



TD-MIXVENT SERIES - Air Performance

Model	Nom. RPM	Volts	Max. Watts	Speed	CFM v Static Pressure (SP) Ins. WG							Max. SP	Duct Dia. Ins.
					0"	0.125"	0.25"	0.375"	0.5"	0.75"	1.0"		
TD 100	2431	120	23	LS	97	81	51	-	-	-	-	.4	4"
	2516	120	26	HS	101	85	57	-	-	-	-	.4	4"
TD 100x	1556	120	20	LS	100	77	48	-	-	-	-	.375	4"
	2096	120	33	HS	135	113	90	53	-	-	-	.55	4"
TD 125	1633	120	24	LS	149	110	73	-	-	-	-	.35	5"
	2146	120	38	HS	197	168	133	86	22	-	-	.55	5"
TD 150	1709	120	54	LS	218	193	163	128	105	24	-	.8	6"
	2289	120	65	HS	293	273	250	227	206	131	35	1.15	6"
TD 200	2322	120	139	LS	476	422	373	317	260	40	-	1.38	8"
	2781	120	184	HS	538	495	458	418	367	190	10	1.625	8"
TD 200x	1935	120	122	LS	419	393	363	327	295	215	107	1.4	8"
	2467	120	169	HS	478	457	432	402	372	285	192	1.75	8"
TD 250	2400	115	162	LS	541	475	418	355	295	218	170	2.03	10"
	3200	115	241	HS	754	715	680	640	606	520	405	2.53	10"
TD 315	2000	115	208	LS	751	670	545	420	285	190	130	1.62	12.4"
	2500	115	335	HS	1050	990	932	850	770	600	420	2.95	12.4"

Performance certified is for installation type D-Ducted inlet, Ducted outlet. Performance ratings do not include the effects of appurtenances (accessories). Speed (RPM or RPS) shown is nominal. Performance is based on actual speed of test.



Soler & Palau USA certifies that the TD range shown herein is licensed to bear the AMCA Seal. The ratings shown are based on tests and procedures performed in accordance with AMCA Publication 211 and comply with the requirements of the AMCA Certified Ratings Program.



The TD-MIXVENT Series fans are California Title 24 compliant and meet ASHRAE 62.2 when installed with 3 way switch and remotely mounted speed control.

LS= Low Speed

HS=High Speed



PV-POWERVENT SERIES - Air Performance

Trade Name	Model No.	Nom. RPM	Volts	Max. Watts	CFM v Static Pressure (SP) Ins. WG								Max. SP	Duct Dia. Ins.	
					0"	0.125"	0.25"	0.375"	0.5"	0.75"	1.0"	1.25"			1.5"
Power Vent-100	PV-100	1400	115	57	108	100	92	85	78	66	52	33	18	1.7	4"
Power Vent-100x	PV-100x	2880	115	84	153	142	130	120	111	96	80	63	34	1.85	4"
Power Vent-125	PV-125	2350	115	58	128	104	85	74	63	47	32	15	-	1.43	5"
Power Vent-125x	PV-125x	2745	115	85	206	190	170	153	135	110	88	62	33	1.77	5"
Power Vent-150	PV-150	2750	115	78	245	205	177	157	129	93	59	-	-	1.2	6"
Power Vent-150x	PV-150x	3075	115	149	438	420	395	368	335	285	240	203	161	2.29	6"
Power Vent-200	PV-200	3100	115	130	402	375	350	327	296	239	179	135	85	1.94	8"
Power Vent-200x	PV-200x	2930	115	180	544	515	485	446	415	360	312	273	230	2.64	8"
Power Vent-250	PV-250	3000	115	200	587	555	525	495	472	412	355	312	270	2.61	10"
Power Vent-250x	PV-250x	3045	115	214	618	595	570	540	510	450	390	340	297	2.8	10"
Power Vent-315	PV-315	2600	115	170	654	605	570	525	487	408	333	265	203	2.21	12.4"
Power Vent-315x	PV-315x	2650	115	370	942	905	859	811	762	622	508	440	390	3.9	12.4"

Performance certified is for installation type D-Ducted inlet, Ducted outlet. Performance ratings do not include the effects of appurtenances (accessories). Speed (RPM or RPS) shown is nominal. Performance is based on actual speed of test.



Soler & Palau USA certifies that the PV range shown herein is licensed to bear the AMCA Seal. The ratings shown are based on tests and procedures performed in accordance with AMCA Publication 211 and comply with the requirements of the AMCA Certified Ratings Program.



*PV 150x and larger ENERGY STAR® qualified.

The PV-POWERVENT Series fans are California Title 24 compliant and meet ASHRAE 62.2 when installed with 3 way switch and remotely mounted speed control.



SWF-SIDEWALL SERIES - Air Performance

Model	CFM v Static Pressure (SP) Ins. WG								
	0"	0.125"	0.25"	0.375"	0.5"	0.75"	1.0"	1.25"	1.5"
SWF-100	119	106	92	78	64	44	26	-	-
SWF-100X	171	162	152	142	118	90	66	46	28
SWF-150	235	221	197	181	168	122	81	60	27
SWF-150X	354	332	310	287	266	230	192	147	96
SWF-200	416	395	368	341	324	287	233	184	132



The SWF-SIDEWALL Series fans are California Title 24 compliant and meet ASHRAE 62.2 when installed with 3 way switch and remotely mounted speed control.

All products manufactured by S&P have undergone extensive tests and quality assurance programs to ensure that the products supplied meet the latest international performance and safety standards. Soler & Palau is an ISO9001 registered company, and has onsite ENAC and AMCA third party accredited test laboratory facilities.

KIT Bathroom Exhaust Kits

Featuring TD-MIXVENT Kits



The TD-MIXVENT fan kits provide all the hardware needed to complete a simple in-line ducted ventilation installation. The kit includes a powerful TD in-line fan, exterior and interior grills, tough flexible aluminium ducting and a roll of duct tape.

The TD-MIXVENT fan kit is the ideal solution for any simple in-line ducted fan installation.

IMPORTANT: If venting in a non-insulated attic space, or in a cold climate, insulated flexible duct is strongly recommended for condensation issues.

Standard Exhaust Kits

KIT-TD100

- 1 TD100 Exhaust Fan
- 1 Plastic round grill (BOR-100)
- 1 Exterior fixed grill (GR-100)
- 4 in. Flexible ducting (GSA) 13 ft.
- 1 Roll adhesive tape (BA)
- Integral Mounting Bracket

KIT-TD100x

- 1 TD100x Exhaust Fan
- 1 Plastic round grill (BOR-100)
- 1 Exterior fixed grill (GR-100)
- 4 in. Flexible ducting (GSA) 13 ft.
- 1 Roll adhesive tape (BA)
- Integral Mounting Bracket

KIT-TD150

- 1 TD150 Exhaust Fan
- 1 Plastic round grill (BOR-150)
- 1 Roll adhesive tape (BA)
- Integral Mounting Bracket
- 1 Air Exhaust Grill

TD Deluxe Exhaust Kits



KIT-TD150-DV

- 1 TD150 Exhaust Fan
- 2 Plastic round grills (BOR-150)
- 1 Y-fitting (SY-6)
- 7 Nylon tie wraps (TW-6)
- Integral Mounting Bracket

All TD kits have standard 7-year warranty.

KIT Bathroom Exhaust Kits

Featuring PV-POWERVENT Kits

S&P PV-POWERVENT Series fans are also available as easy-to-install kits. This ultra powerful bathroom fan offers a choice of single or dual vent exhaust. These kits are used for installations that require long or complicated duct runs. Each kit includes the following:

Standard Exhaust Kits



KIT-PV100

- 1 PV100 Exhaust Fan
- 1 Plastic round grill (BOR-100)
- 4 Nylon tie wraps (TW-4)
- Mounting Bracket

KIT-PV100x

- 1 PV100x Exhaust Fan
- 1 Plastic round grill (BOR-100)
- 4 Nylon tie wraps (TW-4)
- Mounting Bracket

KIT-PV150

- 1 PV150 Exhaust Fan
- 1 Plastic round grill (BOR-150)
- 4 Nylon tie wraps (TW-6)
- Mounting Bracket

All PV kits have standard 8-year warranty.

PV Deluxe Exhaust Kits



KIT-PV100x-DV

- 1 PV100x Exhaust Fan
- 2 Plastic round grills (BOR-100)
- 1 Y-fitting (SY-4)
- 7 Nylon tie wraps (TW-4)
- Mounting Bracket

KIT-PV150-DV

- 1 PV150 Exhaust Fan
- 2 Plastic round grills (BOR-150)
- 1 Y-fitting (SY-6)
- 7 Nylon tie wraps (TW-6)
- Mounting Bracket

KIT-PV200-DV

- 1 PV200 Exhaust Fan
- 2 Plastic round grills (BOR-200)
- 1 Y-fitting (SY-8)
- 7 Nylon tie wraps (TW-8)
- Mounting Bracket

CVK-100 - Convert-a-Kit Bathroom Exhaust Kits



Reduce the noise of your existing bath fan and replace it with a quiet S&P inline fan! S&P's Convert-a-Kit Bathroom Exhaust Kit (CVK-100) includes all of the components that you need to disable your current fan and connect to a new S&P fan. Best of all, you choose which 4" S&P fan is most compatible with your installation!

Features of Convert-a-Kit:

- No ceiling or drywall repairs
- Use existing fan housing and grill
- ENERGY STAR® Qualified (TD models)
- HVI Certified
- UL Listed
- All fans include a five year warranty

The CVK-100 Kit Includes:

- 8 ft. of 4 in. insulated flexible duct
- 4"-3" duct reducer
- 12 ft. 14-2 electrical wire
- Wire nuts
- Cable restraint
- Screws
- 2 Nylon tie wraps.

Bathroom Exhaust Accessories

BOR/BOC-Interior Grill

Exhaust grills for bathrooms, toilets and other small rooms. All models offer an adjustable central valve to regulate the airflow.

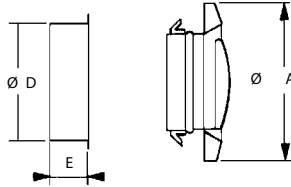

Model	A	D	E	Weight (lbs)
BOR/BOC-100	145	100	50	1
BOR/BOC-125	145	125	50	1
BOR/BOC-150	204	160	50	1
BOR/BOC-200	244	200	50	1

CAR-Backdraft Damper

Backdraft dampers are designed with galvanized steel collars and have light-weight aluminum damper blades. They are spring loaded for positive closure.

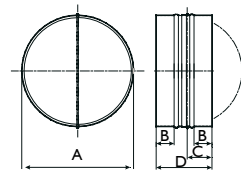

Model	A	B	C	Weight (lbs)
CAR-100	100 3 15/16	80 3 2/16	32 1 4/16	1
CAR-125	125 4 15/16	100 3 15/16	42 1 10/16	1
CAR-150	150 5 14/16	120 4 12/16	52 2 1/16	1
CAR-200	160 6 5/16	120 4 12/16	52 2 1/16	1
CAR-250	200 7 14/16	140 5 8/16	62 2 7/16	1
CAR-315	250 9 13/16	140 5 8/16	62 2 7/16	2

PER-W-Plastic Louvred Shutter

Louvre back-draft shutters manufactured totally from UV stabilized plastic material. Supplied as standard in grey color.

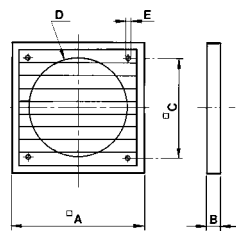

Model	A	B	C	D	E
PER-100	123	12	90	98	4
PER-125	158	15	110	130	4
PER-160	178	20	130	152	4
PER-200	243	21	184	205	5
PER-250	294	26	233	260	5
PER-355	394	26	310	360	5
PER-400	457	26	365	420	5
PER-450	499	31	395	460	5

EPBT-60-Electronic Push Button Timer

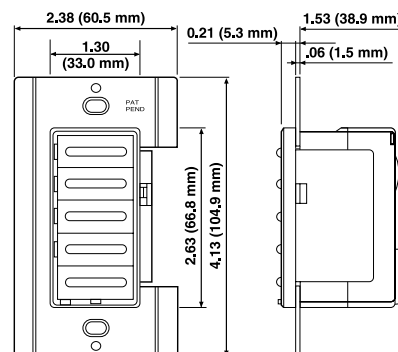



Soler & Palau USA
6393 Powers Ave.
Jacksonville, FL 32217
800.961.7370
800.961.7379
www.solerpalau-usa.com

Soler & Palau Canada
61 A Baywood Road
Toronto, ON M9V 3Y8
866.733.0233
866.358.5346
www.solerpalaucanada.com